

EV[®] DYNACORD[®]

USER MANUAL

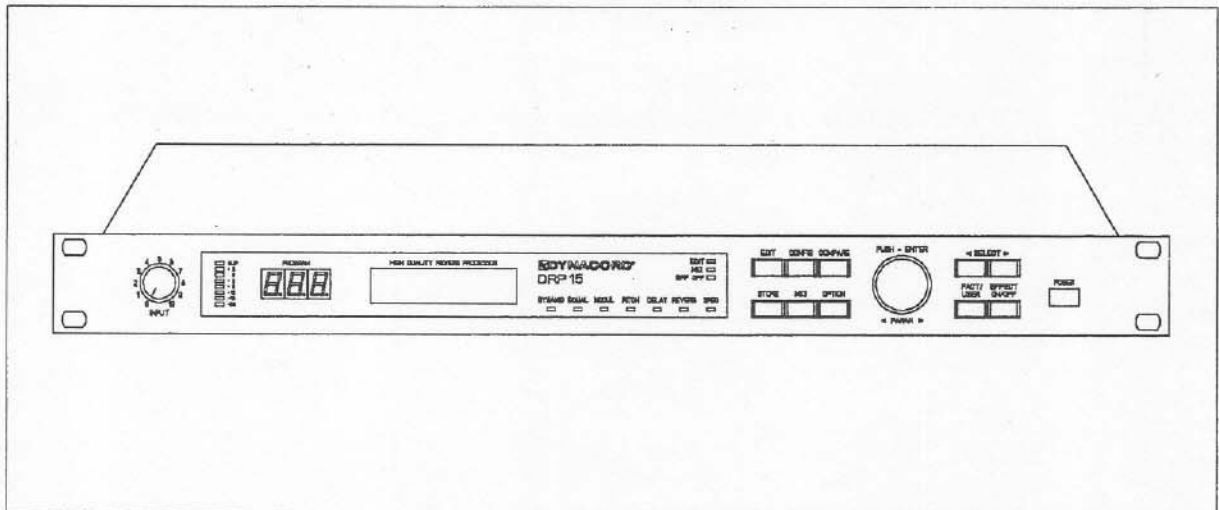

DRP 15

High Quality Reverb Processor

INTRODUCTION

TABLE OF CONTENTS

| CHAPTER | CONTENT | PAGE |
|---------|--|------|
| 1 | INTRODUCTION..... | 1-4 |
| 2 | PANEL DESCRIPTION AND CONNECTIONS..... | 2-1 |
| 2.1 | Front Panel..... | 2-1 |
| 2.2 | Rear Panel..... | 2-3 |
| 3 | SETTING UP THE DRP 15..... | 3-1 |
| 3.1 | Mono in/Mono out..... | 3-1 |
| 3.2 | Mono in/Stereo out..... | 3-1 |
| 3.3 | Stereo in/Stereo out..... | 3-1 |
| 3.4 | Position of the groundlift switch..... | 3-1 |
| 4 | START-UP..... | 4-1 |
| 4.1 | Switching the unit on..... | 4-1 |
| 4.2 | Level setting..... | 4-1 |
| 5 | OPERATION..... | 5-1 |
| 5.1 | Program selection..... | 5-1 |
| 5.2 | Editing..... | 5-2 |
| 5.2.1 | Selection of the effect structure..... | 5-3 |
| 5.2.2 | Editing the parameters..... | 5-3 |
| 5.3 | Compare..... | 5-5 |
| 5.4 | Save and name of programs..... | 5-6 |
| 5.5 | Copy..... | 5-7 |
| 5.6 | Effect Off function..... | 5-7 |
| 6 | EFFECT STRUCTURES..... | 6-1 |
| 7 | EFFECTS AND PARAMETERS..... | 7-1 |
| 7.1 | Effect/Parameter table..... | 7-1 |
| 7.2 | Description of parameters..... | 7-2 |
| 7.2.1 | Direct signal path..... | 7-2 |
| 7.2.2 | Equalizer..... | 7-2 |
| 7.2.3 | Reverb..... | 7-3 |
| 7.2.4 | Modulation..... | 7-9 |
| 7.2.5 | Pitch Shift..... | 7-12 |
| 7.2.6 | Delay..... | 7-14 |
| 7.2.7 | Distortion..... | 7-15 |
| 7.2.8 | Delay Line 1>2..... | 7-16 |
| 8 | OPTION FUNCTIONS..... | 8-1 |

| | | |
|-------|-------------------------------|------|
| 9 | MIDI | 9-1 |
| 9.1 | General description | 9-1 |
| 9.2 | MIDI main menu | 9-2 |
| 9.2.1 | MIDI receive channel | 9-2 |
| 9.2.2 | MIDI program table | 9-2 |
| 9.2.3 | MIDI dump | 9-3 |
| 9.2.4 | MIDI IN monitor | 9-3 |
| 9.3 | MIDI patch menu | 9-4 |
| 9.4 | MIDI data format | 9-6 |
| | MIDI Implementation Chart | 9-11 |
| 10 | REMOTE CONTROL | 10-1 |
| 10.1 | Remote connections | 10-1 |
| 11 | APPENDIX | 11-1 |
| 11.1 | How is reverberation produced | 11-1 |
| 11.2 | What is MIDI | 11-2 |
| 12 | SPECIFICATIONS | 12-1 |
| 12.1 | Specifications | 12-1 |
| 12.2 | Block diagram | 12-2 |
| 12.3 | Wiring diagram | 12-3 |
| 12.4 | Dimensions | 12-4 |
| 13 | SERVICE | 13-1 |
| 14 | WARRANTY | 14-1 |

INTRODUCTION

1. INTRODUCTION

First of all we should like to thank and congratulate you for choosing the digital Multi-effect processor DRP 15 from DYNACORD.

The DRP 15 provides numerous varying effects in 100 pre-set programs and 128 freely programmable memory locations. Besides the familiar and popular DYNACORD reverberation (Room, Plate, Reverb, Gated Reverb, Early Reflections) the DRP 15 comprises echo effects (Delay Line, Stereo Delay, Ping-Pong), modulation effects (Chorus, Flanger, Phaser, Space, Rotor), along with Equalizer, Pitch Shifting, Voice Filter, Distortion etc. A maximum of six effects can be used in the multi-effect structures at one and the same time.

The DRP 15 can be used as a pre-switched unit, e.g. for guitars, or for looping into your mixing console. The inputs and outputs can be switched to -6 dBm or + 4dBm as required, allowing for straightforward adaptation of the DRP 15 to your existing equipment. The flat frequency response of 20 Hz to 20 kHz in the effect line ensures that the effects sound clear and transparent especially as regards the highs.

It goes without saying that the DRP 15 is equipped with a MIDI interface. MIDI can be used to change programmes via remote control, to alter parameters dynamically, to edit parameters, transfer programs to other units and load them back to the DRP 15 again at any time.

This Owner's Manual is meant to help you familiarize yourself with all the DRP 15's other functions. Please read it through carefully and we guarantee that your new DRP 15 multi-effect processor from DYNACORD will give you great pleasure.

IMPORTANT NOTES

ATTENTION: This unit must be protected from damp because of fire risk and the possibility of electric shocks.

1. Make sure that nothing, especially no metal objects, are inserted into the device. This could result in a severe electric shock or malfunction.
2. If the unit is subjected to extreme fluctuations of temperature, e.g. on being transported from outside to a heated room, condensation can form. The unit should not be used until it has reached room temperature.
3. If water or any other liquid is spilt on to the unit accidentally, the unit should be switched off immediately and taken to a servicing facility to be checked.
4. Make sure that the unit is always well ventilated and never exposed to direct sunlight.
5. Do not use sprays to clean the unit as they have a detrimental effect on the unit and could ignite suddenly.
6. The unit contains a backup battery which supplies the RAM if the unit is switched off. This prevents the USER programs from getting lost. The service life of this battery is approx. 5 years. As soon as the voltage drops below a required lower limiting value, following message is shown on switching on: "Service required, change internal battery". In this case please contact your next Service Department. **ON NO ACCOUNT SHOULD YOU CHANGE THE BATTERY YOURSELF!**

PANEL DESCRIPTION AND CONNECTIONS

2. PANEL DESCRIPTION AND CONNECTIONS

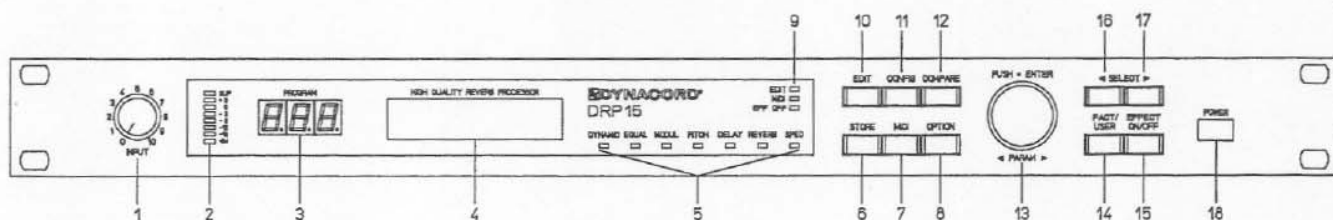

2.1 FRONT PANEL

1, INPUT control

This adjusts the input level of both channels in a range from -80 dB to +21 dB (if the INPUT selector on the rear side is in position LINE) or from -90 dB to +10 dB (INPUT selector in position INSTR).

2, Level indicator

This is for modulation monitoring, whereby the maximum value of the input or output level is always indicated. Another feature is the peak hold function which allows easy level matching.

3, Program number indication

This 3-digit display shows the number of the current program. Presets from the factory are shown with F00 - F99, user programs with No. 001 - 128. During selection of a new program the indicator blinks until the program is activated by ENTER (= pressing of the rotary encoder).

4, Multi-functional display

This is a LC display involving 2 lines with 16 characters each. In PLAY mode the program name (upper line) and effect name (lower line) are indicated. In EDIT mode the parameter name and a graphic and numeric parameter value are indicated. Depending on the current status OPTION menus, status messages, user guide messages etc. appear.

5, Effect LED's

These LED's indicate the effects available in the current program. A blinking LED signalizes that the user is in the parameter level of the corresponding effect.

6, STORE Button

With this button the edited programs can be stored in a user memory place (No. 001 - 128) and the program name can be changed.

For further information please see "SAVE AND NAME OF PROGRAMS", chapter 5.4.

7, MIDI Button

This push-button calls up the MIDI editing mode. After pressing this button, global MIDI settings, program-related MIDI images, MIDI dumps etc. can be made. For more detailed information please see chapter "MIDI" on page 9-1.

8, OPTION Button

This button allows access to OPTION mode where unique settings for the unit can be made or checked. For further information please see OPTION, chapter 8.

9, Status/Mode LED's

These LED's indicate the DRP 15's current status. If the LED EDIT lights up, the EDIT mode is indicated. The LED MIDI lights up when MIDI parameters are being edited and on reception of MIDI data. The LED EFFECT OFF indicates that the effect units has been switched off.

10, EDIT Button

This button changes the operation to EDIT mode. After pressing this button, the first parameter of the active program is shown. Further parameters are accessible via the SELECT buttons. The value of the parameters shown can be changed via the rotary encoder. For further information please see "EDIT", chapter 5.2.

PANEL DESCRIPTIONS AND CONNECTIONS

11, CONFIGURATION Button

This button serves to activate effect structures (configuration). After pressing this button, the name of the current effect structure appears on the display. Select a new structure with the rotary encoder.

For further information please see chapter 5.2.1.

12. COMPARE Button

With the aid of this button you can compare the momentarily edited program with the program in the actual memory location. This button is only active in Edit mode.

For further information please see chapter 5.3.

13, Rotary Encoder with ENTER button

In Play mode a program can be selected by turning the rotary encoder and activated by pushing the encoder (= ENTER). In Edit mode the parameter values can be altered by the rotary encoder. The input of the parameters can be accelerated by turning the encoder and keeping it pressed down at the same time. Generally speaking the rotary encoder serves for faster single-handed operation of the DRP 15.

For further information please see "OPERATION", page 5-1.

14, FACTORY/USER Program Button

With this button you can toggle between the Factory and User memory area. The last active Factory and User program will be selected. The program number can be altered by the rotary encoder (F00 - F99, 001 - 128) and the desired program can be called up by pushing the Encoder(=ENTER).

For further information please see "PROGRAM SELECTION", chapter 5.1.

15, EFFECT ON/OFF Button

Pressing this button will switch off the effect unit and feeds the input signal without effect ("dry") to the output. The LED EFFECT OFF lights up. Pressing this button once more will switch on the effect again; the LED EFFECT OFF goes out. This function can be remote controlled by a foot switch (see rear panel). For further information please see EFFECT ON/OFF FUNCTION, chapter 5.6.

16, SELECT Button <

In play mode this button selects the previous program number (activation by pushing the rotary encoder). In edit mode it is used for selecting parameters (always the previous parameter).

17, SELECT Button >

In play mode this button selects the next program number (activation by pushing the rotary encoder). In edit mode it is used for selecting parameters (always the next parameter).

18, POWER switch

This button is used to switch the DRP 15 on and off.

PANEL DESCRIPTION AND CONNECTIONS

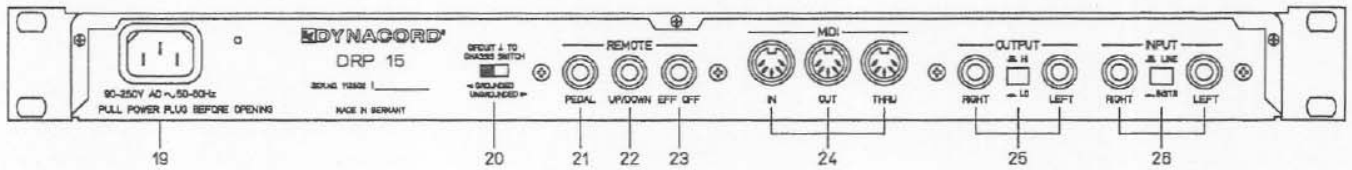

2.2 REAR PANEL

19, Mains socket

The DRP is started up by connecting the enclosed mains cable to the mains socket. The DRP 15 is designed for mains voltages of 90 V to 260 V, meaning that fluctuations in mains voltage present no problem!

20, Groundlift switch

The groundlift switch serves to prevent hum loops. If the DRP 15 is used together with other units in a 19" rack, the switch should be put on "GROUNDED". If the DRP 15 is used together with units which have different earthing potentials the switch should be put on "UNGROUNDED".

21, Remote socket PEDAL

A foot controller FR 5 (special accessory) from DYNACORD can be connected here. This enables real time control of certain parameters. The control parameter for each DRP 15 program can be programmed separately. For further information please see "REMOTE CONTROL", chapter 10.

22, Remote socket UP/DOWN

A foot switch FS 500 (special accessory) from DYNACORD can be connected here to switch over programs. The user can determine which programs are to be selected in the OPTION menu. For further information please see "REMOTE CONTROL", chapter 10.

23, Remote socket EFFECT OFF

A foot switch FS 12 (special accessory) from DYNACORD can be connected at this socket to switch the effect unit on or off (same function as EFFECT OFF on the front panel). Activating the foot switch for the first time switches the effect off, re-activation switches the effect back on again.

24, MIDI sockets IN/OUT/THRU

If the socket MIDI IN is connected with a MIDI-controlled unit, the DRP's programs can be selected from there. Parameter alterations are also possible, whereby the DRP 15 parameters can be assigned to the MIDI controllers at random. The MIDI OUT socket serves as a data output, e.g. to transfer the contents of the USER memory to a MIDI data recorder or another DRP 15. Data can thus be saved and re-loaded via MIDI IN at any time. All MIDI data received is passed on unchanged via the socket MIDI THRU.

For further information on MIDI please see chapter 9.

25, Sockets OUTPUT LEFT/RIGHT and level switch HI/LO

These are the DRP 15's stereo outputs. A level switch can be used to select a nominal output level of +10 dBu (HI) or 0 dBu (LO). If only one of the two jack sockets is used, this results in a MONO sum from the left and the right channel.

26, Sockets INPUT LEFT/RIGHT and selection switch LINE/INSTRUMENT

These are the DRP 15's stereo inputs. The selection switch can be used to choose between LINE input (+4 dBu) or Instrumental input (-6 dBu, high-Z). In order to feed in a MONO signal simply connect just one of the two input sockets.

SETTING UP THE DRP 15

3. SETTING UP THE DRP 15

To achieve the best results with the DRP 15, the unit must be connected properly. To start the unit up connect the enclosed mains connection cable with the DRP 15's mains socket and your power supply.

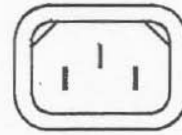

3.1 Mono in / Mono out

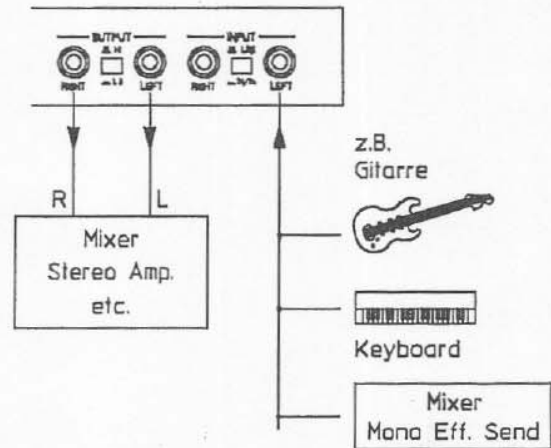
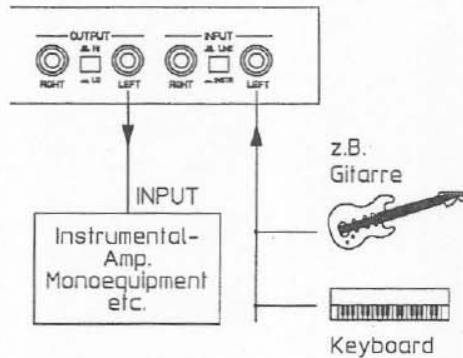

3.2 Mono in / Stereo out

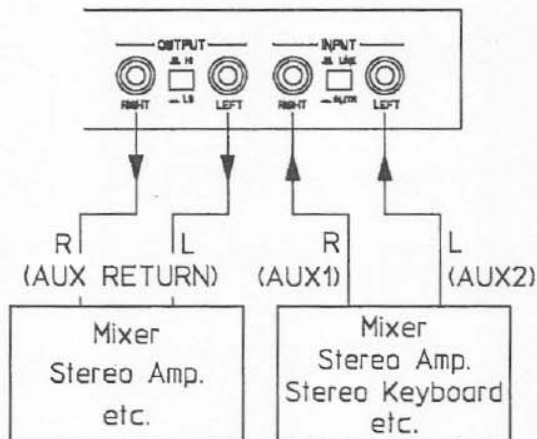

Important:

- Always use well-screed audio cables.
- To avoid high frequency losses the feeding lines, especially to the inputs, should not be longer than 10 m.
- Do not position the unit directly on or under a powerful power amplifier, TV monitor or the like, as the leakage field of the transformers in such devices could induce hum in the electronics of the DRP 15.

3.4 Position of Groundlift switch

The groundlift switch serves to avoid hum loops. Dependent on the operational condition it should be switched into following positions:

UNGROUND: If you use the DRP 15 together with units with different earthing potentials.

GROUND: If you use the DRP 15 together with other units in a 19" rack.

CIRCUIT 1 TO CHASSIS SWITCH



◀ GROUND
UNGROUND ▶

4. START-UP

4.1 SWITCHING THE UNIT ON

1. The unit is switched ON via the POWER switch (18).
2. For a duration of two seconds the following appears on the display:
3. Subsequently the DRP is ready for operation and is in Play mode. The following may appear on the display:

POWER



F 01

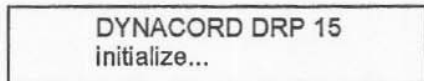

F 01

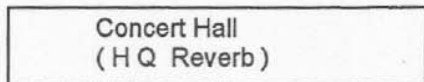

ATTENTION!

If the following message appears after switching the unit on:

please contact your next Service Department in order to have the internal backup battery changed.

In this case the battery voltage has dropped below a required lower limiting value and there is no guarantee that your program data will be maintained when the unit is switched off!

F 01

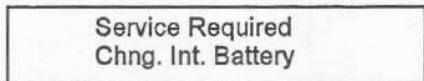

4.2. LEVEL SETTING

1. First set the INPUT selection switch depending on which equipment has been connected.
2. While the level is being adjusted via the INPUT control (1), keep checking the maximum indication on the level meter. The optimum value is 0 dB. If the control range should prove insufficient, press the INPUT selection switch (at the rear) to INSTR. The CLIP LED indicates internal overdriving and should on no account be lit up.

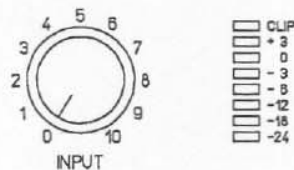

INSTR: This range is selected for low levels, such as electric guitar or bass. The inputs have a high impedance.

LINE: This range is selected for medium to high levels, e.g. AUX- OUTPUT, audio equipment with line level, drums etc.

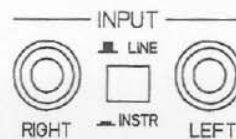

OPERATION

5. OPERATION

The DRP 15 is operated via an rotary encoder with a push function (ENTER) and 10 function keys.

The DRP 15 contains 6 different modes which can be selected directly from any state.

1. PLAY MODE:

Mode after switching on
Program selection mode
Activation with key FACT/USER

2. EDIT MODE:

Parameters are edited here.
Indication via EDIT LED
Activation via EDIT key

3. CONFIG MODE:

Setting of the effect structure (configuration)
Indication via EDIT LED
Activation via CONFIG key

4. STORE MODE:

Storing and copying programs
Title editing
Activation via STORE key

5. MIDI MODE:

Setting global MIDI parameters and program specific MIDI parameters
Indication via MIDI LED
Activation via MIDI key

6. OPTION MODE:

Editing functions pertaining to equipment
Activation via OPTION key

5.1 PROGRAM SELECTION

Programs can only be selected when the DRP 15 is in Play mode. This is the case after switching on, for example.

The DRP 15 contains 100 fixed factory programs

F 00 - F 99

and in addition, 128 freely programmable User programs

001 - 128

1. To call up a memory place please press the FACTORY/USER program button (14) in order to switch to the respective program area.

(not necessary if you are already in the program level required)

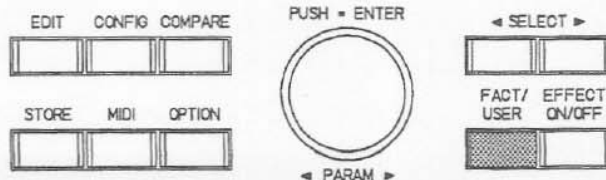

2. Either look for the required program with the **Rotary Encoder (13)** or with the two **SELECT keys (17) and (18)**.

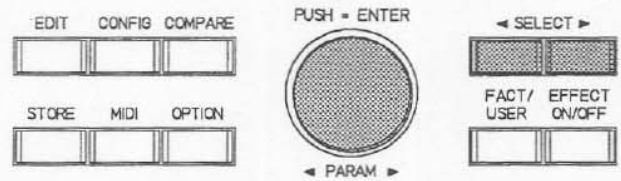

3. The program name selected appears on the display and the program number blinks.
4. Activate the program by pressing the **Rotary Encoder (ENTER) (13)**.

F 29

CHORUS
(H Q Modulation)

The Rotary Encoder is a fine detent control without left or right limit stop and with an integrated key. It works like an electronic step counter which counts one detent every time it is activated. If keeping pushed during rotation, 10 units per detent are counted.

In the Play mode it is used to select a memory place, otherwise it is used to perform all value inputs.

Pressing the rotary encoder (= ENTER) confirms all inputs.

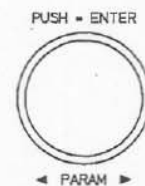

For information on program selection via remote control please see chapter "REMOTE CONTROL", page 10-1.

IMPORTANT:

- Hectic and powerful rotating the encoder does not accelerate the counting process and possibly damages the detent mechanic.

5.2 EDITING

The DRP 15 has a large number of editing possibilities, meaning that the user is free to create completely individual effect programs.

For one, an effect structure (configuration) can be selected, as described in 5.2.1, and for another, the parameters can be edited (5.2.2).

If you should wish to process one or more parameters within an existing program without changing the effect structure, go straight on to 5.2.2

IMPORTANT:

- While editing, use the table on page 7-1. This is an important editing aid and tells the user:
 - 1 Which and how many parameters are in each effect structure.
 - 2 The value range of each parameter.

OPERATION

5.2.1 SELECTION OF THE EFFECT STRUCTURE

The effect structure is the skeleton of every program. It determines which individual effects are to take part. The active effects are constantly indicated by the Effect LED's. The CONFIG mode also indicates the name of the effect structure. For a description of all effect structures please turn to chapter 6.

- 1 To edit effect structures press the key CONFIG (11)
- 2 You are now in CONFIG Mode. The EDIT LED lights up, and the effect structure of the program selected appears on the display. If you only want to check which effect structure is active without wishing to alter it, simply proceed from point 2 to chapter 5.2.2 directly.

- 3 Select one of the 10 effect structures via the rotary encoder (13)

- 4 The following may appear on the display:

- 5 The selected effect structure is active immediately and the EDIT LED begins to blink ¹⁾.

The selected effect structure activates the parameter chain of this structure (see 5.2.2).

¹⁾ The blinking LED signalsizes that the program has been altered.

5.2.2 EDITING THE PARAMETERS

Parameters are altered in EDIT mode. For a description of all parameters please turn to chapter 7.

- 1 Press the EDIT key (10)
- 2 You are now in EDIT mode. The EDIT LED lights up and the name and the value of the first parameter in the active program appear on the display. A graphic indication of the parameter value gives constant information as to one's current position in the parameter range. A blinking EFFECT LED shows the current individual effect.
- 3 The rotary encoder (13) can now be used to alter the parameter value. If the rotary control is kept pressed while turning, the parameter input is accelerated. (greater step width).

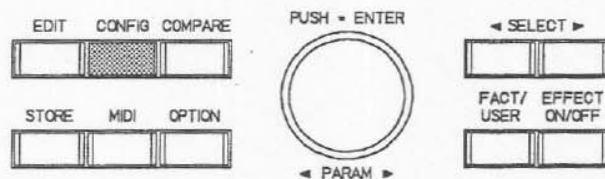

F 01

SELECT CONFIG:
H Q Reverb

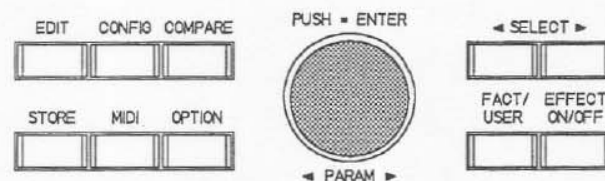

F 01

SELECT CONFIG:
Delay + Reverb

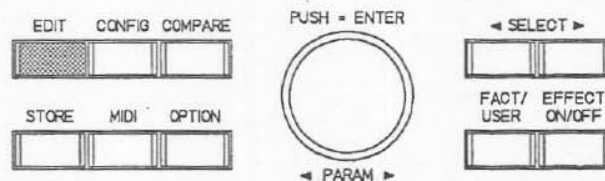

F 01

REVERB LEVEL:
■■ 50

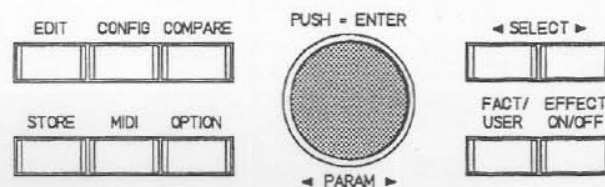

- 4 The set value appears on the display and the change is immediately audible. The EDIT LED then blinks to show that the program has been changed. If you do not wish to alter further parameters, proceed directly to point 7.

- 5 The SELECT keys (16) and (17) take the user directly to the next parameter. The EDIT key takes the user to the next individual effect in the structure. Then a different EFFECT LED blinks.

Note:

- By repeated pushing of the EDIT key you switch to the next single effect in the active configuration. For the order please see description of the effect structures in chapter 6.

F 01

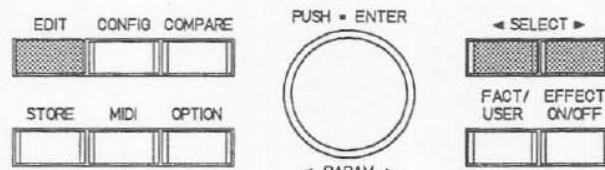
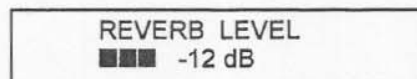

- 6 The following may appear on the display:

Points 5 and 6 can be repeated as often as required.

- 7 Pressing the key FACT/USER (14) takes the user back to Play mode.

NOTE! Your program alterations have not yet been stored and will be lost at the next program change!

F 01

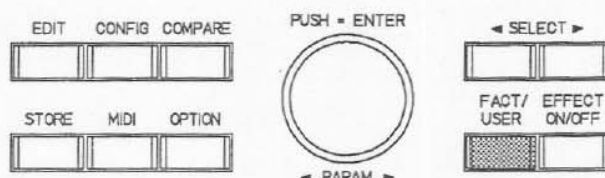
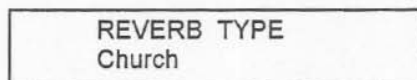

- 8 The program name appears again on the display. The EDIT LED continues to blink. There are several different possible ways of continuing:

- if you should wish to give the program a new name, proceed directly to chapter 5.4.
- if you should wish to store the edited program in a memory place, proceed to chapter 5.4.
- if you should wish to continue to alter parameters, start again at step 1.
- if you should require the original program again, press the rotary encoder (ENTER). The altered parameter values are thus deleted. The EDIT LED goes off.

F 01

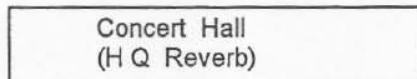

OPERATION

5.3 COMPARE

With the aid of the COMPARE button (12) you have the possibility, to compare the edited program with the original program in the memory. You have a clear overview of all changes made compared with the original program. The COMPARE function is only possible as long as the edited program has not been stored.

- 1 Push the COMPARE button (12) to hear the actual basic program.

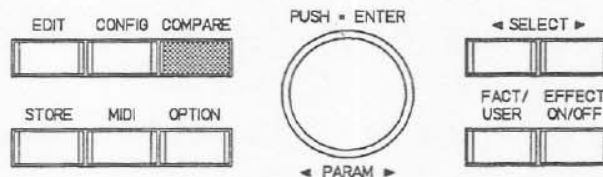

The display will show e.g.

Now the original program is active and the stored parameter value of the last selected parameter during editing is shown in the display.

F 01



- 2 Press the COMPARE button (12) once more to switch to your edited program.

The display will show the last selected parameter e.g.

This example means that the REVERB LEVEL has been changed from original -25dB to -12dB.

F 01

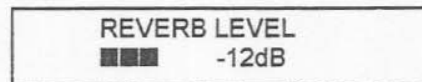

- 3 Now you can proceed with editing. You can repeat the compare function at will as often as required.

5.4 SAVE AND NAME OF PROGRAMS

No matter whether you are editing a program (parameter) or wish to save the alteration of a name, the saving procedure is always the same. The same applies to saving MIDI patches. All values are stored under the desired user program place.

The storing procedure is initiated and ended via the STORE key (6). You can prevent storing by cancelling the procedure with any MODE key (FACT/USER, EDIT, CONFIG, MIDI, OPTION).

- 1 Press STORE (6) to initiate the storage procedure.

IMPORTANT!

- Storage is only possible on user programs. Factory programs ("F" preceding the program number) can be altered at will, but are never deleted. If the storage procedure is started on a FACTORY program, as in the example below, the DRP 15 automatically suggests the same program number in the USER memory.
- Changing the name of a program does not effect a change in parameters.

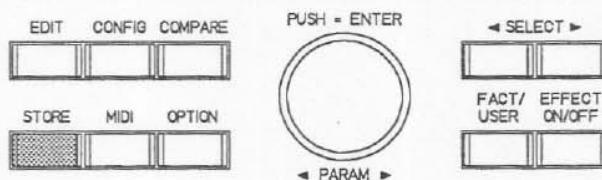

The following may appear on the display:

F 04

STORE TO USER 04
Studio Classic

- 2 If you wish to save the program in the place suggested by the DRP 15, without altering the name, proceed directly to step 6. If you only wish to alter the name but not the program place, proceed to step 4.
- 3 Select the desired memory place via the rotary encoder (13). You can continue with step 6 if the name is not to be altered.
- 4 Select the title line (2nd line) via the SELECT keys (16) and (17).
- 5 The desired characters can be set on the blinking cursor position via the rotary encoder (13). For a space or to delete a character press the rotary encoder (13). The SELECT keys (16) and (17) can be used to move the cursor backwards and forwards and to move back to the 1st line.
- 6 Final storage occurs by pressing the key STORE (6) again.

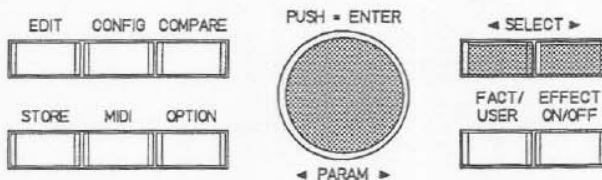
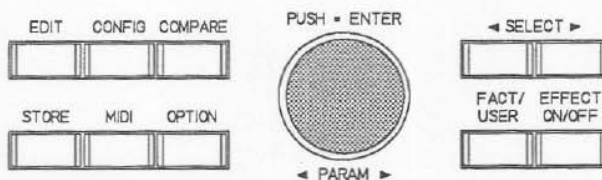

F 08

STORE TO USER 08
Homerecord 1

NOTE! The previous program occupying that particular memory place will be deleted! Therefore make sure that the destination program number corresponds with the number you require. The storage procedure can be cancelled by pressing any MODE key at random.

The following may appear on the display:

008

Homerecord 1
H Q Reverb

OPERATION

5.4 COPY

In the DRP 15 it is possible to copy programs from one memory place to any other.

The procedure is similar to that of storing a program.

- 1 In Play mode select the program you wish to copy (see program selection 5.1)
- 2 Press the key STORE (6) to initiate the copying procedure.

The following may appear on the display:

- 3 Use the rotary encoder (13) to select the memory place where you wish to copy your program.
- 4 Storing occurs when the STORE key (6) is pressed again.

The copy procedure can be cancelled by pressing any other MODE key at random.

- 5 "Program stored" appears on the display (for approximately 1 second) once storage has been completed.
- 6 Then the DRP 15 returns to Play mode. The copied program is active in the new memory place.

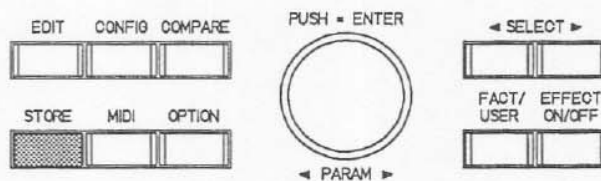

F 02

STORE to USER 24
Cathedral

F 02

Program
stored ...

024

Cathedral
(H Q Reverb)

5.6 EFFECT-ON/OFF-FUNCTION

To switch the effect signal off, activate the EFFECT ON/OFF key (15). You then hear the direct signal without effect (dry).

The appropriate LED signalizes this state to the user.

Press the key EFFECT ON/OFF (15) again to switch the effect back on. The EFF OFF LED goes off and the signal has the effect again.

Informations for remote control of these functions please see page 10-1, "REMOTE CONNECTIONS".

IMPORTANT!

The original signal remains unchanged during the Effect-On/off- function. It only appears at the output when the ORIGINAL LEVEL of this program is turned on.

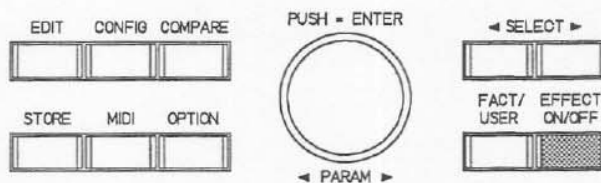

6. EFFECT STRUCTURES

The DRP 15 has 10 different effect structures (configurations). These provide the basis for drawing up a program. Each effect structure consists of various individual effects and the corresponding parameters. The selection and number of parameters is ideally suited for creating the effect in question.

For a description of the individual parameters please turn to chapter 7. The effect/parameter table in chapter 7.1 shows which individual effects and parameters are available in which effect structure.

All the effect structures are listed and explained in more detail in this chapter.

IMPORTANT:

- The corresponding examples for the individual effect structures are shown in paranthesis.

- | | |
|---------------------------|--------------------------|
| A Direct only | F Delay + Reverb |
| B High Quality Reverb | G Pitch + Delay + Reverb |
| C High Quality Modulation | H Multi Effect |
| D Pitch Shift | I Instrumental Effect |
| E Long Delay | K Delay Line 1 > 2 |

A DIRECT ONLY (e.g. F 00)

This structure merely serves to loop an input signal through to the output directly. The output volume can be stored at the same time. This type of program serves to provide dynamic volume control via MIDI commands - (see MIDI).

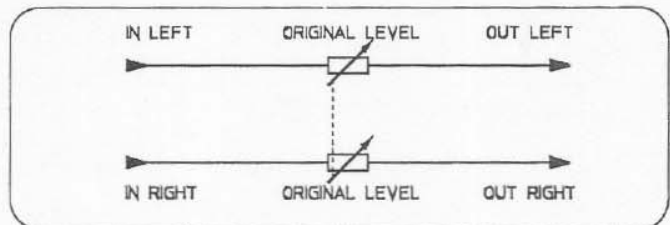

B HIGH QUALITY REVERB (e.g. F 01)

This structure serves to simulate stereophone room images. It is thus possible to generate an unusual variety of different types of reverberation. A subsequent EQ section can be used to control the basses and trebles of the reverb signal.

The total capacity of the DRP 15's effect chip is available for reverb creation, allowing for the very best reverb quality with this particular structure. There is a choice of nine different types of reverb, whereby the type "All parameters" comprises 11 echo parameters. This can be used to provide any conceivable type of reverb characteristics.

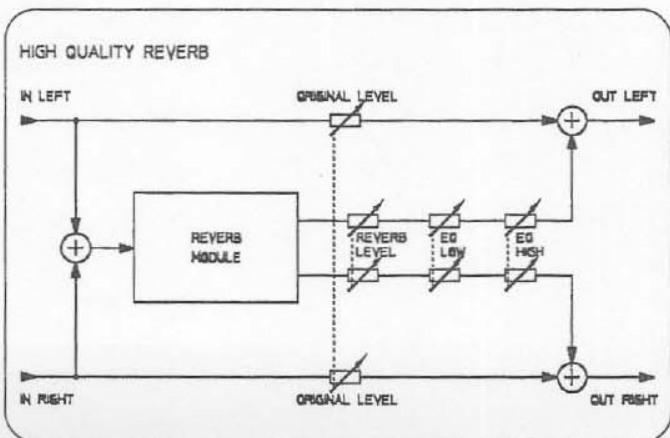

EFFECT STRUCTURES

C HIGH QUALITY MODULATION

In this effect structure a number of delays work with their own, independent modulators to draw up any conceivable chorus, flanging, phasing and rotor effects.

Here too, the DRP 15's total computer capacity is on hand, making for particularly "warm" and "rich" modulation sounds.

The subsequent EQ section also enables the user to set the modulated signal's basses and trebles as required.

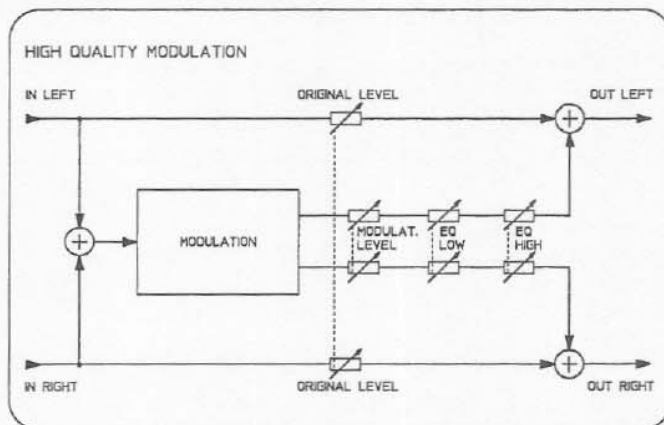

D PITCH SHIFT

This effect can be used to add two effect signals to the signal, which have a shifted pitch compared with the direct signal.

In this way, whole chords can be produced with e.g. one note.

The subsequent EQ section can also be used in this configuration to control the effect signal's basses and trebles as required.

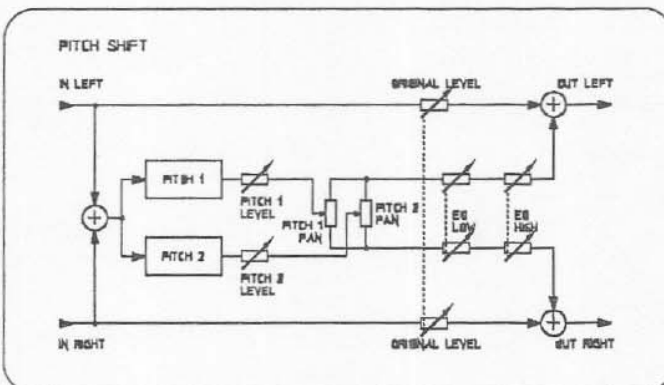

E LONG DELAY

This structure is a delay line with feedback and a subsequent EQ section. Here you can generate delays with long distances (over 1 sec.!). The bass and treble frequencies can be adjusted at will.

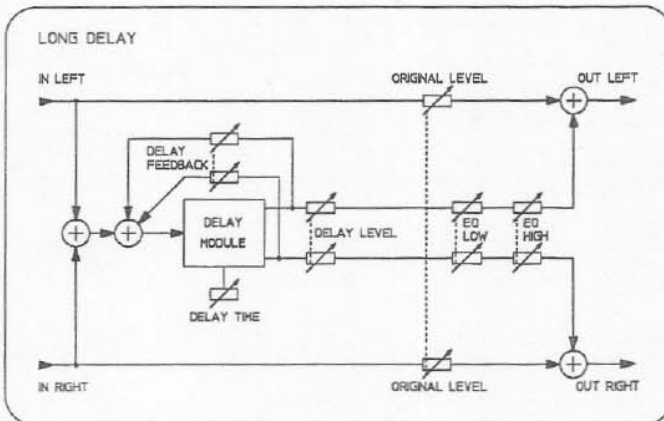

F DELAY + REVERB

A delay module and a reverb module are switched parallel in this structure.

As the reverb module is within the echo-feedback, this produces a special type of echo effect with reverb which particularly enhances live performances.

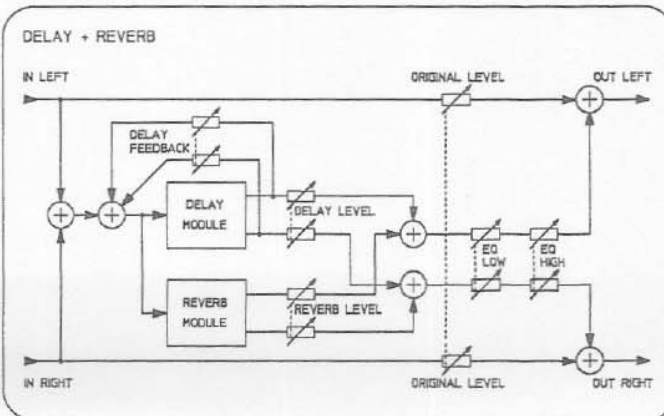

G PITCH + DELAY + REVERB

Here a Pitch Shifter is combined with a reverb structure and a delay. The transposed signal and the direct signal can be processed in the subsequent REVERB MODULE in order to create a feeling of space. A delay effect can be mixed in additionally.

Here, too, basses and trebles can be controlled via a subsequent EQ section.

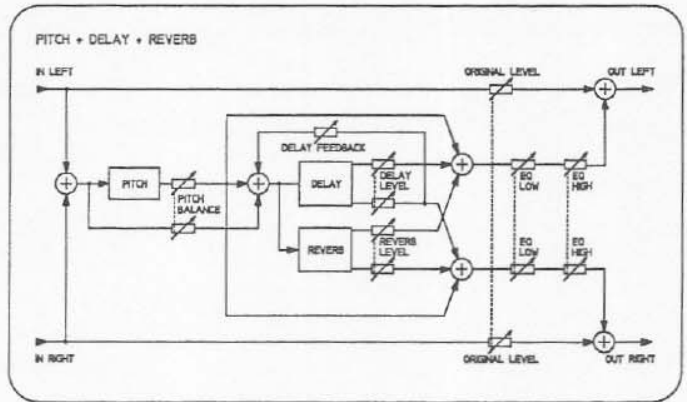

H MULTI EFFECT

The MULTI EFFECT consists of four individual effects. These include Modulation, Delay, Reverb and Equalizer. Here, too, there is a wide variety of editing possibilities, as already described previously.

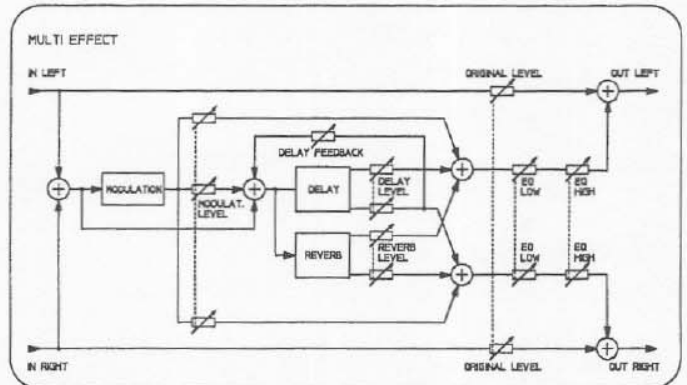

I INSTRUMENTAL EFFECT

This effect is mainly of interest when it comes to guitars and bass. It consists of six different individual effects, namely Distortion, Voice Filter, Modulation, Delay, Reverb and Equalizer. There is also a wide choice of editing possibilities in this structure.

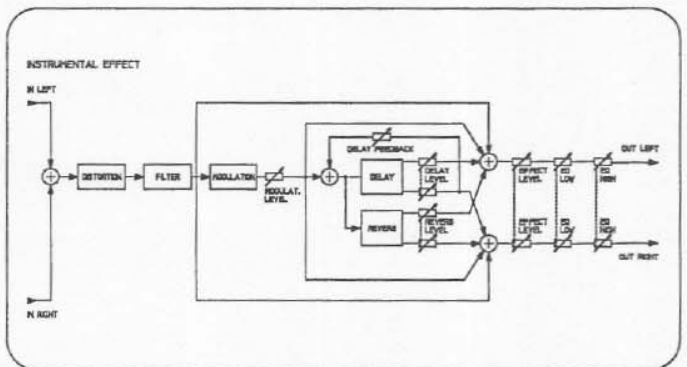

K DELAY LINE 1 > 2 (e.g. F 99)

This is a delay line with one input and two outputs. A maximum delay time of 1 second is to be set for the two outputs. In the signal path there is also an EQ section which enables the user to control basses and trebles as required.

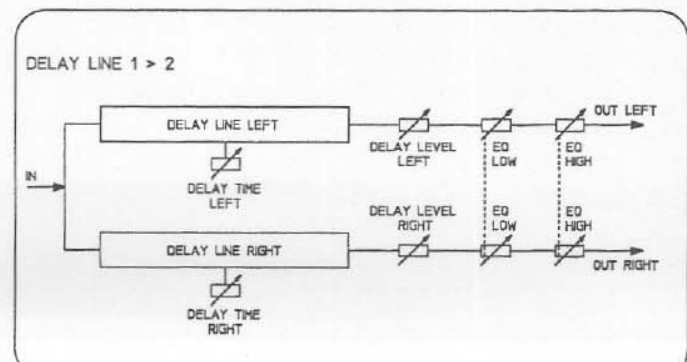

7.2 DESCRIPTION OF THE PARAMETERS

Different manufacturers often give the same function different names. In order to avoid confusion and to give the user more details about the parameters' tasks and settings, this chapter contains a description thereof.

7.2.1 DIRECT SIGNAL PATH

The DRP 15 contains an direct signal path in stereo. This is required when the DRP 15 is used as a pre-switched unit. One parameter is available for this signal path:

ORIGINAL LEVEL

This is used to set the volume of the direct signal for both the left and the right channel.

Valuation range: 0dB - -79dB, -OFF-

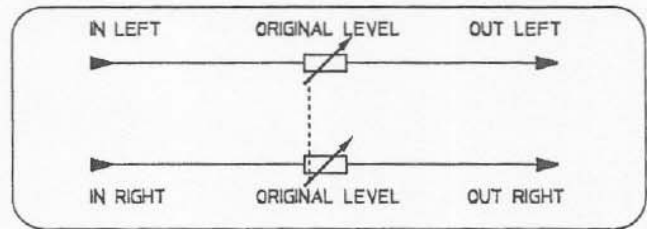

F 01

| | |
|----------|--------|
| ORIGINAL | LEVEL |
| ■■■ | -20 dB |

Important

- If the direct signal is not audible and if -OFF- appears on the display instead of dB values, the DRP 15 is switched to "Original OFF" in OPTI-ONS Mode. Switching over to "Original ON" makes the direct signal appear at the output with the volume programmed originally. (see "OPTION", Chapter 8)

7.2.2 EQUALIZER

The DRP's effect path is equipped with a 2-band equalizer which serves for tone control of the effect signal. The basses and trebles can be raised or lowered by a maximum of 14 dB. The equalizer has two parameters:

EQ LOW

Raising or lowering the basses is set with this parameter. The corresponding filter has low-shelving characteristics.

Valuation range: - 14dB - +14dB

EQ HIGH

Raising or lowering the trebles is set with this parameter. The filter has high-shelving characteristics.

Valuation range: -14dB - + 14dB

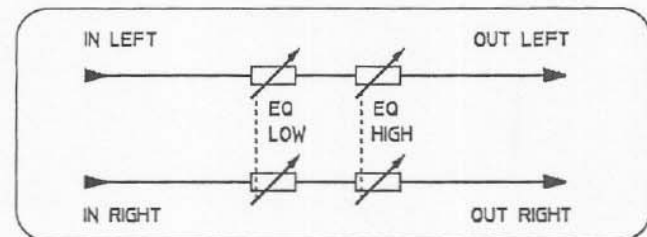

F 27

| |
|------------|
| EQ LOW |
| ■■■ - 1 dB |

F 27

| |
|-------------|
| EQ HIGH |
| ■■■■ + 7 dB |

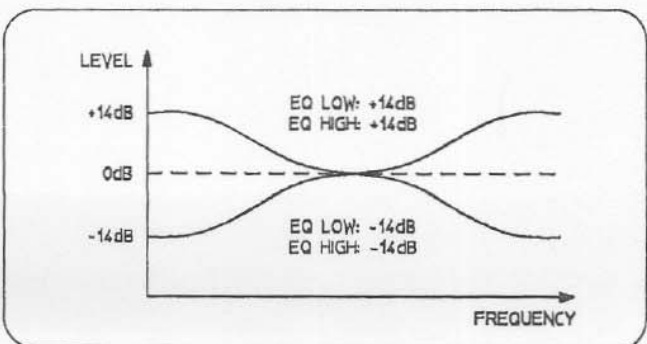

EFFECTS AND PARAMETERS

7.2.3 REVERB

The reverberation is the most complex of the effects produced by the DRP 15. It consists of a variety of parameters which are described below.

Depending on the type of reverb selected, different parameters appear. The diagrams below illustrate which parameters are available for which type of reverb.

If you should still be relatively unfamiliar with effect units and the creation of reverberation, read this chapter through carefully, along with the Appendix 11.1 "How is reverberation produced", before editing a program.

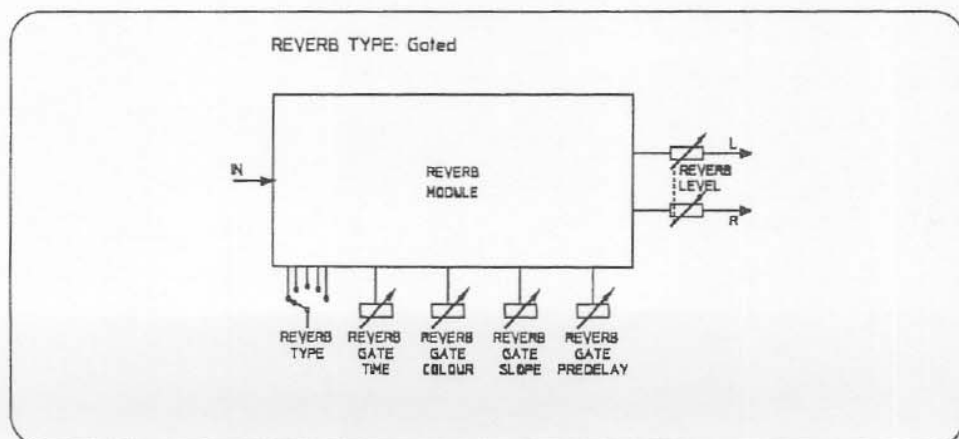
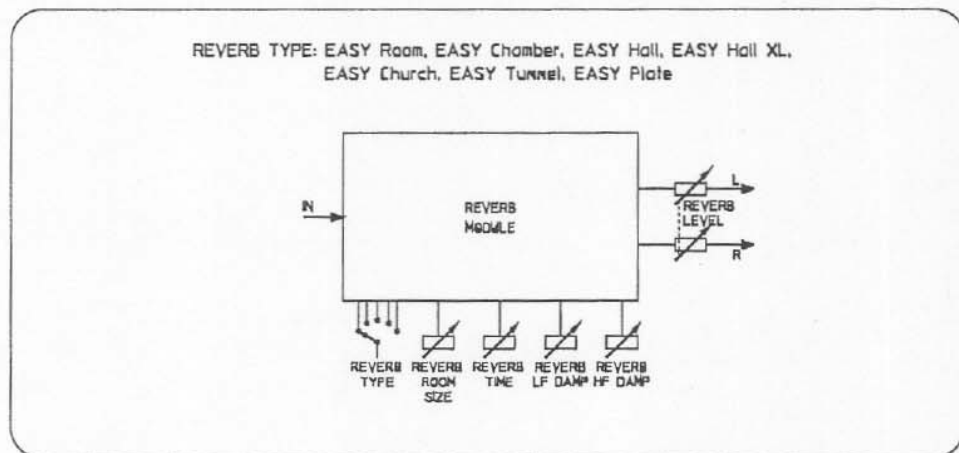
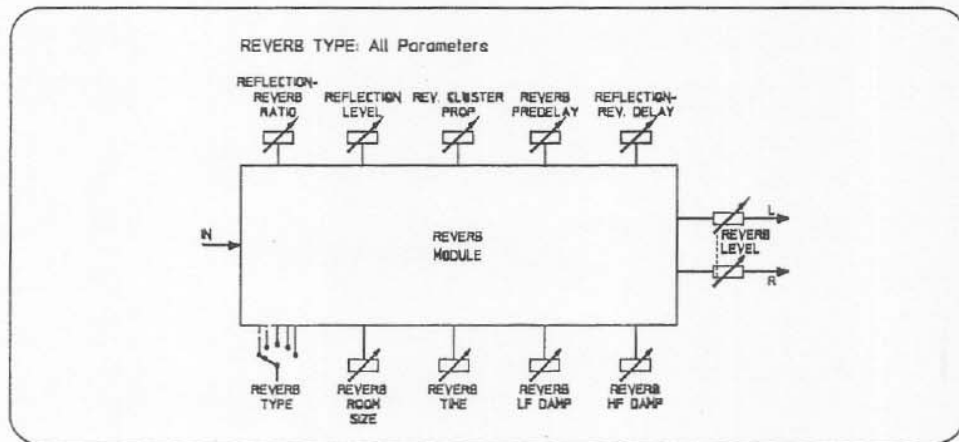

EFFECTS AND PARAMETERS

REVERB LEVEL

This parameter determines the volume of the reverb. The reading appears in dB.

Valuation range: 0 dB -- 48 dB, -OFF-

REVERB LEVEL
■■■■ - 12 dB

REVERB TYPE

The type of reverb is determined by this parameter. Depending on the geometry of the room or the propagation medium, there are differing reverb characteristics which can be selected here.

Settings: **All parameters**
 EASY Room
 EASY Chamber
 EASY Hall
 EASY Hall XL
 EASY Church
 EASY Tunnel
 EASY Plate
 Gated

REVERB TYPE
EASY Room

The following parameters depend on the "REVERB TYPE" set. "All Parameters" means that the user has access to all reverb parameters. If you want a quick result, simply select one of the EASY types. These provide fewer parameters, but the complexity of the reverb remains the same. Depending on the type of reverb, a number of optimum internal parameters are pre-determined.

REVERB ROOM SIZE

This is used to set the size of the room. The readings appear in cubic metres.

Valuation range: 0.0 cbm - 124 990 cbm

F 01

REVERB ROOM SIZE
■■■■■ 91120 cbm

REVERB TIME

The duration of the reverberation is the time which elapses until the reverberation has faded to one thousandth (-60 dB) of the direct level. Reverb Time can be used to set the duration of the reverb. Reverb Time is a feedback factor similar to feedback with delays. The reading appears in seconds.

Valuation range: 0.0 s - 19.9 s

F 01

REVERB TIME
■■■ 2.4 s

EFFECTS AND PARAMETERS

REVERB LF DAMP

This parameter is very important for the characteristics of various rooms together with HF Damp. They are responsible for the reverb's frequency response.

REVERB LF DAMP determines the damping of the basses compared with the reverb time.

The reverb time multiplied by the Damp value set gives the reverb time of the basses.

e.g. REVERB LF DAMP: 0.5 \rightarrow 8 s \times 0.5 = 4 s

In this case the basses would already have faded after half of the normal reverb time.

Valuation range. 0.0 - 1.1

F 01

REVERB LF DAMP
■ ■ x 0.5

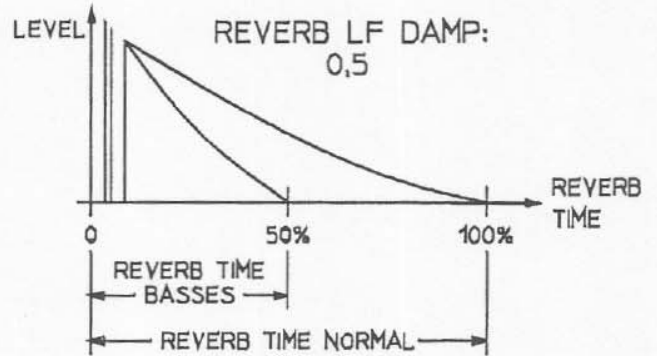

REVERB HF DAMP

Together with LF Damp this parameter is of great importance for the characteristics of various rooms. They are responsible for the frequency response of the reverberation.

REVERB HF DAMP determines the damping of the trebles compared with the reverb time.

The reverb time multiplied by the set Damp value gives the reverb time of the trebles.

e.g. REVERB HF DAMP: 0.5 \rightarrow 8 s \times 0.5 = 4 s

In this case, the trebles would already have faded after half of the normal reverb time.

In practice, this would correspond with a vaulted cellar with rough walls, for example. The trebles die down quickly, while the basses take longer to fade.

This would not apply in an empty, tiled room where trebles and basses fade at the same time (LF = 1.0, HF = 1.0).

Valuation range: 0.0 - 1.0

F 01

REVERB HF DAMP
■ ■ x 0.5

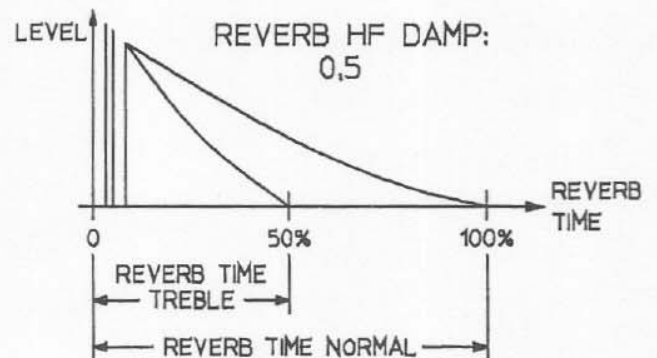

REFLECTION - REVERB RATIO

This parameter determines the relationship between the first reflections and the real reverb proportion.

Valuation range: Revb. only
 -48dB - +48dB
 Refl. only

F 01

REFL-REV RATIO
 + 28 dB

First reflections and reverb clusters can be mixed at random or, in extreme cases, can be switched off altogether.

In practice, "soft" rooms (negative dB values) and "hard" rooms (positive dB values) can be realized.

REFLECTION TYPE

These parameters are used to determine the type of the first reflections. There are 10 different clusters to choose from.

F 01

REFLECTION TYPE
 Hall 1

- Settings:
- Room
 - Chamber
 - Hall 1
 - Hall 2
 - Hall 3
 - Plate
 - Spring
 - Reverse
 - Left > Right
 - Expand

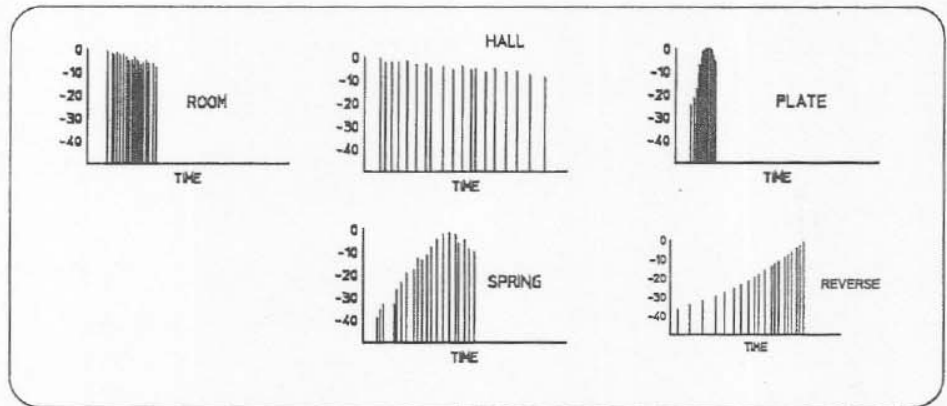

With the setting "Left > Right" the first reflections in the stereo image move from left to right, and with "Expand", to the left and the right, starting from the middle.

REVERB CLUSTER PROPORTION

Determines the geometrical features of a room or reverb medium. There are 6 proportions to choose from.

F 01

REVERBLAT PROP
 Cave

1. **CATHEDRAL** - Acoustically speaking, a very favourable, block-shaped room (e.g. church, cathedral)
2. **CAVE** - A flat, relatively low room (e.g. subterranean garage, cellar).
3. **CUBE** - An even, cube-shaped room (e.g. a small, but high room, a high warehouse).
4. **TUBE** - A long, almost cylindrical room, (e.g. subway, tunnel, bunker, wine cellar).
5. **PLATE** - Simulates the effect of a reverb plate (quick transient response).
6. **ROOM+PLATE** - A combination program consisting of reverb plate and room reverberation.

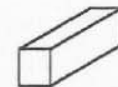

CATHEDRAL



CAVE



CUBE



TUBE



PLATE

EFFECTS AND PARAMETERS

REVERB PREDELAY

The Predelay parameter sets the time between the direct signal and the use of the real reverberation. The reading appears in ms.

Valuation range: 0 ms - 240 ms

In practice, this parameter gives the size of a room and the distance to the sound source.

F 01

REVERB PREDELAY
■ 50 ms

REFLECTION REVERB DELAY

This parameter serves to determine the time delay between the first reflections and the reverberation. The readings appear in ms.

Valuation range: 0 ms - 100 ms

If the parameter is set at 00 ms, the reverb starts at the same time as the first reflections. First reflections and reverb thus mingle.

F 01

REFL - REV - DELAY
■ 25 ms

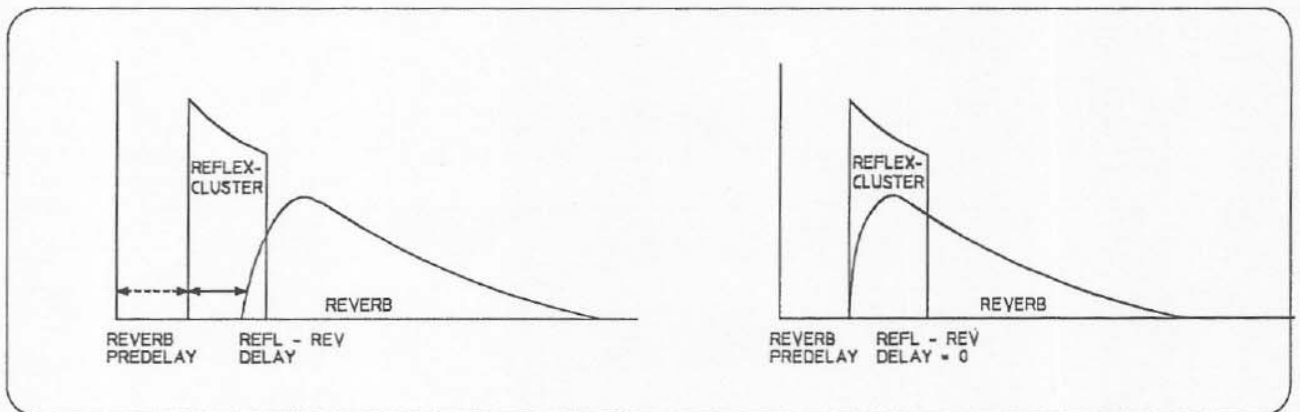

REVERB GATE TIME

This parameter only appears if the REVERB TYPE "Gated" has been selected. It indicates the opening time of the gate in milliseconds.

Valuation range: 10 ms - 340 ms

F 01

REVB GATE TIME
■■■ 260 ms

REVERB GATE COLOUR

This parameter is used to select the "colour" of the Gated Reverb.

The larger the set value, the more dense is the sequence of the individual reflections.

The readings appear in relative values.

Valuation range: 1 - 10

F 01

REVB GATE COLOR
■ 6

REVERB GATE SLOPE

This is also a parameter which only appears in connection with "Gated". The switching off characteristics or the decay of the Gate is determined by Slope according to the Gate Time set.

Valuation range: -10 - 10

-10 = Reverse

0 =

10 = Normal

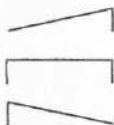

F 01

REVB GATE SLOPE
■■■ 5

REVERB GATE PREDELAY

This determines the time between the direct signal and the beginning of the reverb in "Gated Reverb". The readings appear in ms.

Valuation range: 0 ms - 200 ms

F 01

REVB GATE PREDLY
■ 50 ms

EFFECTS AND PARAMETERS

7.2.4 MODULATION

The modulation section comprises effects such as Chorus, Flanger, Phaser, Rotor etc. A number of delay lines are controlled by independent modulators to make the direct sound "broader" and "warmer", or to produce unusual, artificial colourations.

The varying types of modulation are described as follows:

CHORUS:

The Chorus effect is basically a modulated delay. The delayed signal is modulated via an LFO, whereby the necessary delay time lies between 10 and 30 ms. In the DRP 15, there is a chorus with up to 6 independent "voices" which can each be modulated differently. The result is a "multiplication" of the sound fed in.

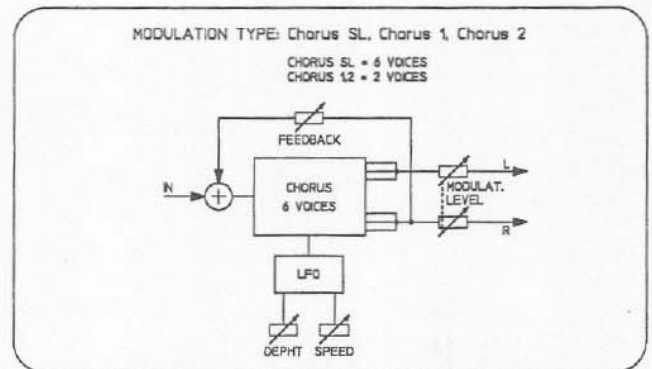

FLANGER:

The flanging effect is also based on a mixture between delayed and non-delayed signals. The delay time in this case is shorter than with Chorus, however, which means that the effect is more in the normal sound sphere. The cyclical shift of two signals which are identical in principle results in phase cancellations, so-called comb-filter effects. Modulation via an LFO causes these cancellations to shift, resulting in Flanging.

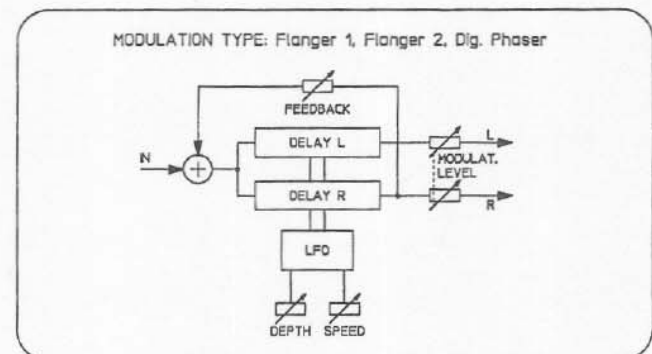

PHASER:

The Phaser is based on the Flanger structure but also possesses other settings as well.

ROTO FLANGER:

The Roto Flanger can be used to simulate rotor or Leslie effects. It is based on the Flanger principle, but also possesses additional taps within the delay line. Modulation of the delay via an LFO simulates rotating loudspeakers.

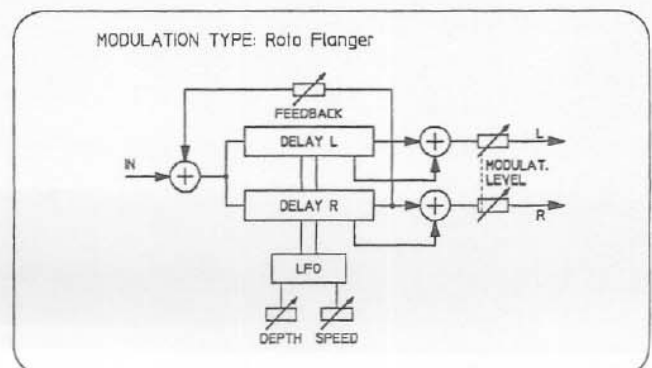

SPACE:

The Space effect is also based on the principle of a modulated delay. In this case, however, two LFO's are in action, whereby the LFO2 is coupled to the LFO1. This means multiple modulation of the delayed signal, the signal being mixed with the direct signal subsequently. This creates a stronger sound colouration than with the modulation effects described hitherto.

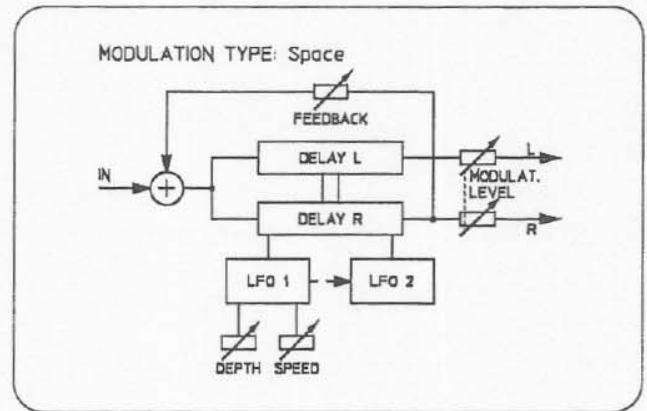

EFFECTS AND PARAMETERS

MODULATION LEVEL

This parameter determines the volume of the modulation effect. The readings appear in dB.

Valuation range: 0 dB - -48dB, -OFF-

F 01

MODULAT LEVEL
■■■■ -12 dB

MODULATION TYPE

The various modulation types can be set here. For further details please turn to the chapter entitled "MODULATION".

Settings: **Chorus SL**
 Chorus 1
 Chorus 2
 Space
 Flanger 1
 Flanger 2
 Phaser
 Roto Flanger

F 01

MODULAT TYPE
Chorus SL

Multi Effect: **Stereo Chorus**
 Mono Chorus
 Stereo Flanger
 Mono Flanger
 Stereo Phaser
 Mono Phaser

MODULATION DEPTH

This parameter serves to set the modulation depth or width. The readings appear in relative values.

Valuation range: 0 -10

F 01

MODULAT DEPTH
■■■■ 10

MODULATION SPEED

This parameter determines the modulation speed or frequency. The readings appear in Hz.

Valuation range: 0.1 Hz - 10.0 Hz

F 01

MODULAT SPEED
■ 2.5 Hz

MODULATION FEEDBACK

This parameter determines the strength of the feedback. If a negative value is set, a phase inversion occurs within the feedback loop. Readings appear in %.

Valuation range: -99% - +99%

F 01

MODULAT FEEDB
■■■ 50%

7.2.5 PITCH SHIFT

The Pitch Shifter is used to add up to two additional tones to the direct signal. The interval can be set from minus one octave to plus one octave. Fine-tuning of $\pm 50\%$ of a semitone is also possible.

The following parameters are available:

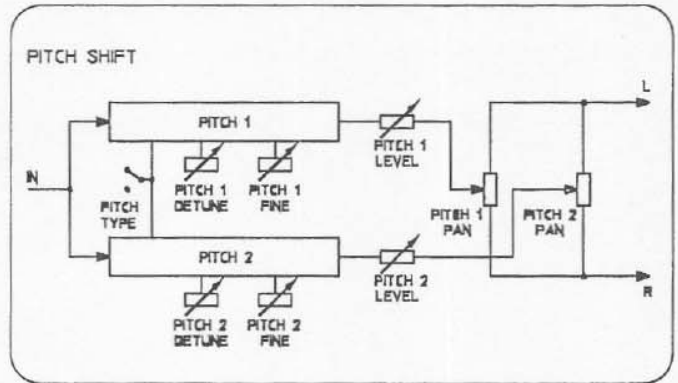

PITCH 1 LEVEL

This parameter determines the level of the first signal transposed.

The setting is made in dB.

Valuation range: 0dB - -48dB, -OFF

F 01

| | |
|--------|-------|
| PITCH1 | LEVEL |
| ■■■■■ | 0 dB |

PITCH 1 PAN

With this control you can position the pitch shifter 1 in the stereo sound image.

The setting is in relative values.

Value range: 10 L, L = R, 10 R

F 01

| |
|-------------|
| PITCH 1 PAN |
| ■ 5 L |

PITCH 1 DETUNE

This parameter is used to transpose the pitch of the direct signal upwards or downwards (maximum - 1 octave higher or lower). The parameter determines the first transposition. (Pitch Shift 1).

The readings appear in steps of 1 semi-tone.

Valuation range: -12 - +12

F 01

| | |
|--------|--------|
| PITCH1 | DETUNE |
| ■■■ | 6 |

PITCH 1 FINE

This parameter effects fine-tuning or de-tuning of the added note in the first pitch shifter. This occurs in steps of cents. (1 Cent = 1 hundredth of a semi-tone). The readings appear in %.

Valuation range: -50% - + 50%

F 01

| | |
|--------|--------|
| PITCH1 | FINE |
| ■■■ | + 25 % |

EFFECTS AND PARAMETERS

PITCH 2 LEVEL

This parameter determines the level of the second signal transposed.

The setting is made in dB.

Valuation range: 0 dB - -48dB, -OFF-

F 01

PITCH2 LEVEL
■■■■ 0 dB

PITCH 2 PAN

With this control you can position the pitch shifter 2 in the stereo sound image.

The setting is in relative values.

Value range: 10 L, L = R, 10 R

F 01

PITCH 2 PAN
■■ L = R

PITCH 2 DETUNE

This parameter is used to transpose the pitch of the direct signal upwards or downwards (maximum - one octave up or down). The second transposition is determined by the parameter (Pitch Shift 2).

The readings appear in steps of 1 semi-tone.

Valuation range: -12- +12

F 01

PITCH 2 DETUNE
■■■ 6

PITCH 2 FINE

This parameter effects fine-tuning or detuning of the note added in the second pitch shifter. This occurs in steps of cents. (1 Cent = 1 hundredth of a semi-tone). The readings appear in %.

Valuation range: -50%- + 50%

F 01

PITCH2 FINE
■■■ + 25 %

PITCH TYPE

There are two possible processing modes in the Pitch Shifter:

FAST Pitch
H Q Pitch

In the setting "Fast Pitch" an extremely fast algorithm is available to prevent the time delays of the transposed signal from becoming audible.

In the "High Quality Pitch" a somewhat longer, more complex algorithm is used. This improves the quality of the transposed signal.

Your personal taste and the sound material on hand determine which type is chosen.

F 01

PITCH TYPE
Fast Pitch

7.2.6 DELAY

The delay effect basically consists of one, or two, delay lines with adjustable feedback on the input.

It can be used to create fading echoes, ping-pong effects, doubling etc.

The following parameters are available:

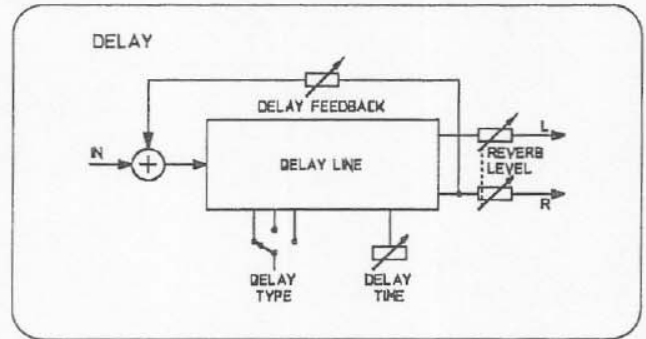

DELAY LEVEL

Determines the volume of the delay section. The readings appear in dB.

Valuation range: 0dB- -48 dB, -OFF-

F 01

| |
|--------------------------|
| DELAY LEVEL ■■■■ 0 dB |
|--------------------------|

DELAY TYPE

There is a choice between the following Delay types:

- Mono
- Stereo 1
- Stereo 2
- Ping-pong

In "Mono" the delay times are identical in the left and right channel.

The "Stereo" setting creates slightly shifted delays for both outputs. In "Stereo 2" there are 2 feedbacks available, which have a fixed ratio.

The "Ping-Pong" setting creates delays in the right and left channel alternatively.

F 01

| |
|------------------------|
| DELAY TYPE Pingpong |
|------------------------|

DELAY TIME

This parameter is used to set the delay time or the time in milliseconds elapsing between each individual delay.

Valuation range: 1 ms - 260 ms
 1 ms - 600 ms (in Delay + Reverb)
 1 ms - 1048 ms (in Long Delay)

F 01

| |
|-----------------------|
| DELAY TIME ■ 60 ms |
|-----------------------|

DELAY FEEDBACK

Here the user can control the strength of the effect feedback to the input. In practice greater values increase the number of repetitions.

The readings appear in %.

Valuation range: +0% - +99%

F 01

| |
|-----------------------------|
| DELAY FEEDBACK ■■ + 50 % |
|-----------------------------|

EFFECTS AND PARAMETERS

7.2.7 DISTORTION

The DRP 15 is equipped with a distortion module which provides both tube-type and transistor-type distortion sounds.

A compressor is also included in the distortion module and it has a fixed link with the control DISTORTION. The amount of compression and distortion is always adjusted together.

The following parameters are available:

DISTORTION

This is used to select the intensity of the distortion. The higher the set value, the stronger the distortion of the signals.

The readings appear in relative values.

Valuation range: -OFF-, 1-12

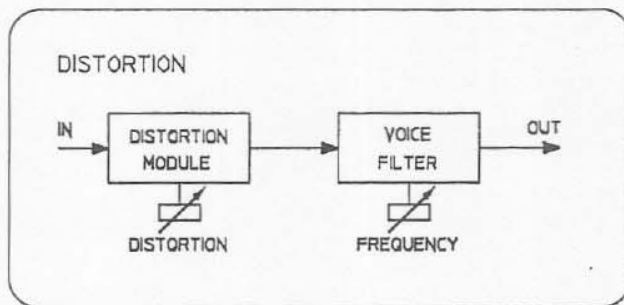

F 01

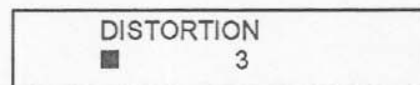

VOICE FILTER

This filter serves to alter the colour of the distorted signal. It is a low-pass filter with an emphasized part in the pass-band. The filter cutoff-frequency is adjustable. In the case of low values, only the deep frequencies are allowed to pass through, which emphasizes the bass tones. The higher the set value, the more harmonics are contained in the signal. "OFF" means that the Filter is switched off.

The frequency readings appear in kHz.

Valuation range: 1.0 kHz - 7.0 kHz, -OFF-

F 01

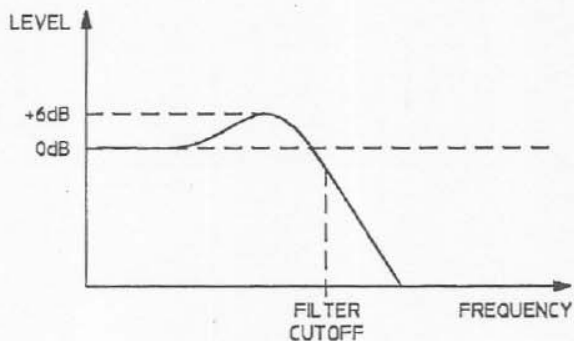

EFFECT LEVEL

This control determines the level of the whole effect signal in the configuration "Instrumental effect". The special arrangement of the individual effects in this structure necessitate this parameter, in order to set the effect ratio.

The readings appear in dB.

Valuation range: 0 dB - -60 dB, -OFF-

F 01

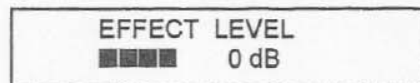

7.2.8 DELAY LINE 1 > 2

This is a delay line with one input and two outputs. The delay time or the signal running time and the volume can be set and stored separately for each output. A delay line is extremely useful when it is a matter of equalizing signal running times in large-scale sound reinforcement systems.

The following parameters are available:

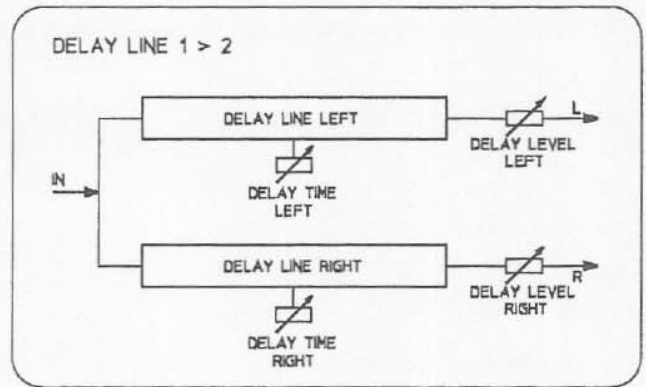

DELAY LEVEL LEFT

Determines the level of the delayed signal in the left channel.

The readings appear in dB.
Valuation range: 0dB - -48 dB, -OFF-

F 01

DELAY LEV LEFT
■■■■ - 12 dB

DELAY LEVEL RIGHT

Determines the level of the delayed signal in the right channel.

The readings appear in dB.
Valuation range: 0dB - -48dB, -OFF-

F 01

DELAY LEV RIGHT
■■■■ 0 dB

DELAY TIME LEFT

This is for setting the delay time or signal running time in the left channel. The readings appear in milliseconds, feet, inches, metres or centimetres.

Valuation ranges: 0 ms - 1048 ms
0 ft. - 1179 ft.
0 in. - 14155 in.
0 m - 359 m
0 cm - 32750 cm

F 01

DELAY TIME LEFT
■■■■ 800 ms

DELAY TIME RIGHT

This is used for setting the delay time or signal running time in the right channel. The readings appear in milliseconds, feet, inches, metres or centimetres.

Valuation ranges: 0 ms - 1048 ms
0 ft. - 1179 ft.
0 in. - 14155 in.
0 m - 359 m
0 cm - 32750 cm

F 01

DELAY TIME RIGHT
■ 270 ms

DELAY TIME UNIT

Here the user can choose the unit for the delay time. Distance settings are automatically calculated into delay times.

Settings: milli-sec.
feet
inch
meter
centimeter

F 01

DELAY TIME UNIT
milli - sec.

OPTION

8. OPTION FUNCTIONS

The Option programs comprise a whole number of important additional functions and pre-settings, such as how the DRP 15 should start after being switched on, whether the direct signal should be switched on or off, how the VU display should be set, etc.

- 1 Press the key **OPTION** (7) to activate the Option Program.
- 2 The Option Program used last appears on the display, e.g.:
- 3 Find the Option required using the two **SELECT** keys (16, 17).
- 4 The rotary encoder is used to set the Option values (13).
- 5 An Option program can be interrupted by pressing another **MODE** key (e.g. return to Play Mode by pressing **FACT** or **USER**).

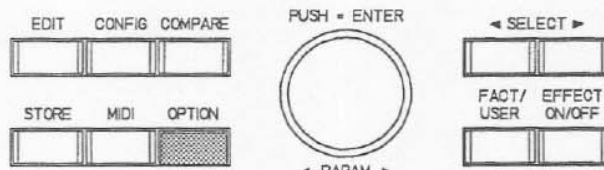

F 01

LCD CONTRAST
*** +3 ***

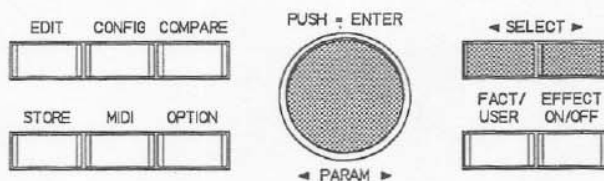

SWITCHING THE DIRECT SIGNAL ON/OFF

This function permits the user to use the DRP 15 as a pre-switched unit or looped device.

If you connect your instrument directly to the inputs of the DRP 15, the direct signal should be switched on, thus reaching the loudspeaker/amplifier via the DRP 15.

If the DRP 15 is looped into the effect path of a mixing desk, the direct signal should be switched off, as it already reaches the master outputs in the mixing desk.

ORIGINAL ON:

The direct signal is switched on and appears in the stored volume at the output. The DRP 15 can thus be used as a pre-switched unit.

ORIGINAL OFF:

The direct signal is switched off with all programs (parameter **ORIGINAL LEVEL**). It appears in the display as "-OFF-". The stored values are of course preserved. This is for looping the DRP 15 into a mixing desk.

F 01

DRP CONFIG
Original On

INDICATION OF THE SOFTWARE VERSION NUMBER

The display shows the software version of the DRP 15's processor, e.g. version 1.0.

F 01

DYNACORD DRP 15
Software V 1.0

SELECTION OF POWER ON MODE

TO FACTORY 1:

On being switched on and after reset, the DRP 15 always reports with the program F01.

TO LAST PROGRAM:

The DRP 15 always reports with the last program used, or with the status with which it was last switched off (except COPY, STORE, OPTION).

F 01

DRP 15 POWER ON
to Factory 1

SETTING THE LCD CONTRAST

The LCD contrast or viewing angle can be adjusted between -10 (from below) and +10 (from above).

F 01

LCD CONTRAST
*** + 7 ***

DISPLAY MODE OF THE LEVEL INDICATOR

WITH PEAK:

The Peak-Hold Function is switched on. This will help you for setting up the level.

NO PEAK:

The Peak-Hold Function is switched off. The level display works normally.

SLOW:

In this setting the level display works with a long time constant, i.e. the decay of the indication is more slowly when the signal level is reduced.

F 01

VU DISPLAY MODE
with peak

FOOTSWITCH TABLE

In this table the sequence for a program selection with the UP/DOWN footswitch (e.g. FS 500) can be determined. Max. 20 program numbers can be assigned.

In the lower line of the display you can select between "Step" and program number with the SELECT buttons (16, 17). The next step or the appropriate program number is set via the rotary encoder.

F 01

FOOTSWITCH TABLE
Step 1: F31

OPTION

Following Settings Are Possible:

| Step No. | DRP 15 program |
|---------------|----------------|
| STEP 1 | F 00 |
| . | . |
| . | . |
| . | F 99 |
| . | 001 |
| . | . |
| . | . |
| Step 20 | 128 |
| | |
| Footsw. Table | Off |

End

- For the program change with footswitch no table is used. The programs are called up in the order F00 - F99, 001 - 128.

- Here the table end is set if not all 20 possible inputs are used.

Example of a table with 5 steps:

- Step 1 : F31 (Factory program)
- Step 2 : 103 (User program)
- Step 3 : 094
- Step 4 : F50
- Step 5 : F51
- Step 6 : End (table end)

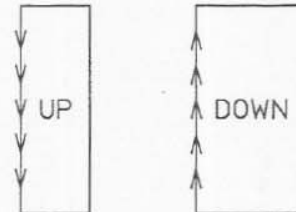

SELECTING THE PARAMETER VALUES

Here the units for the parameters REVERB ROOM SIZE and REVERB TIME can be selected.

IN CBM + SECONDS:

The unit for REVERB ROOM SIZE is cubic meters and for REVERB TIME in seconds.

IN RELATIVE VALS:

The parameters REVERB ROOM SIZE and REVERB TIME are given in percents.

Here the units for the parameter DELAY TIME are set.

IN MILLISECONDS:

The unit for DELAY TIME is milliseconds.

IN BEATS PER MIN:

The unit for DELAY TIME is beats per minute (bpm).

F 01

REVERB SIZE + TIME
in cbm + seconds

F 01

DELAY TIME
in milliseconds

9. MIDI

The MIDI connection is made via the MIDI sockets IN/OUT/THRU (24). The MIDI functions in the DRP 15 allow the unit to be controlled externally. Due to the versatile and flexible possibilities, all the functions can be controlled from another MIDI unit (e.g. computer, sequencer, keyboard..) e.g.

- program change
- changing certain parameters
- switching the effect signal ON or OFF
- all controls (remote control of DRP 15)

...and much more.

There are two different MIDI menus:

1. The MIDI MAIN MENU (see 9.2) to set all general MIDI data and for MIDI-dump.
2. The MIDI PATCH MENU (see 9.3) which enables the user to allocate MIDI Patches to any program at random in Edit Mode, i.e. which parameters are to be controlled by which MIDI controllers (MIDI standard).

If you should still be unfamiliar with MIDI operation, we suggest that you read about MIDI standards and interfaces in MIDI books, computer or music journals etc. to gather general information initially.

There is also a brief explanation in the appendix of chapter 11.2

9.1 GENERAL DESCRIPTION

- 1 Press the MIDI key (7) to reach the particular MIDI menu.

- the MIDI MAIN Menu is accessible from the normal Play Mode.
- the MIDI PATCH Menu is only accessible from Edit Mode.

The MIDI Mode is indicated in that the MIDI LED lights up.

- 2 The MIDI Function appears in the upper line of the display (title).

The parameters to be adjusted appear in the lower line, e.g.:

- 3 The individual MIDI functions within a menu, and several parameters within one parameter line are stepped through via the two SELECT keys (16, 17).

- 4 The rotary encoder is used to set the MIDI parameters.

All settings are active immediately.

A confirmation via ENTER is only necessary for MIDI dump.

- 5 You can leave the MIDI Menu by activating any other Mode key (FACT, USER, EDIT...)

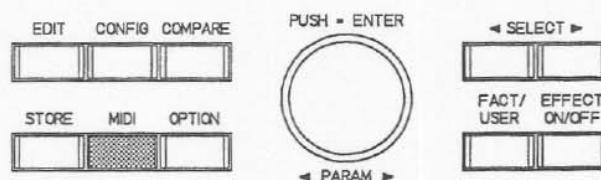

F 01

MIDI RECEIVE
CHANNEL : 02

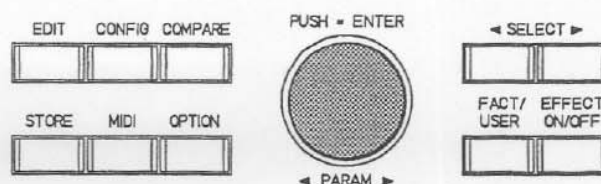
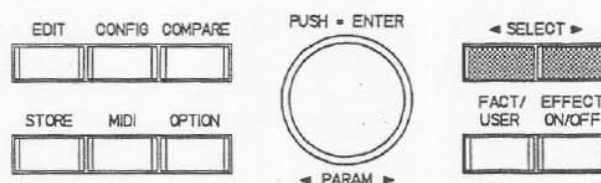

MIDI

9.2 MIDI MAIN MENU

You can reach the MAIN MIDI Menu by pressing the key MIDI (7) from the Play Mode.

There are 4 MIDI functions within this menu. They can be selected successively using the SELECT keys (16) and (17).

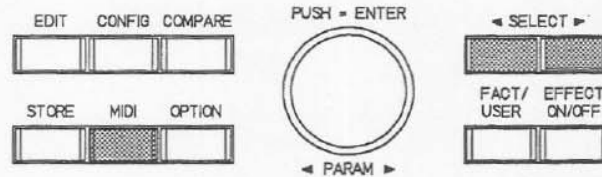

9.2.1 MIDI RECEIVE CHANNEL

This function is used to set the MIDI channel on which the DRP 15 is to receive MIDI data. This setting is also valid for receiving and transmitting system exclusive messages (SysEx). The following appears on the display, e.g.:

F 01

MIDI RECEIVE
CHANNEL : 2

The following settings are possible via the rotary encoder:

- OFF** - The DRP does not react to any MIDI data. SysEx is switched off.
- OMNI** - The DRP receives MIDI data on all 16 MIDI channels. SysEx messages are sent on Channel 1.
- 1 - 16** - The DRP 15 only receives MIDI data on the MIDI channel selected between 1 and 16. This setting is also valid for transmitting SysEx messages.

If the DRP 15 is programmed to MIDI reception, the MIDI LED lights up as soon as data is transmitted to the DRP 15. Thus the MIDI LED also serves to check that the MIDI connection is correct.

9.2.2 MIDI PROGRAM TABLE

This MIDI function can be used to draw up an allocation table in which the 128 general MIDI program numbers are assigned at random to 128 of the DRP's programs. The display shows e.g.:

F 01

MIDI PRG TABLE
001 = F89

This example means that the reception of a MIDI PROGRAM CHANGE with the number 001 calls up a program in the DRP 15 with the number F89.

The following settings are possible:

| MIDI NO. | | DRP 15 program |
|----------|---|----------------|
| 001 | | 001 |
| . | | . |
| . | | . |
| . | | 128 |
| . | = | F00 |
| . | | . |
| . | | . |
| . | | F99 |
| 128 | | - |

- Direct User *)** - The MIDI program numbers 001-128 call up the DRP 15's user programs 001 - 128 (without using the table).
- Direct Factory *)** - The MIDI program numbers 1-99 call up the DRP 15 FACTORY programs F01-F99. The MIDI numbers 100-128 all call up the program F00. (the table is not used)
- Progr Change Off** - The DRP 15 does not react to any MIDI PROGRAM CHANGE commands.

*) Via bank select (MIDI controller 0) you can toggle between the USER and FACTORY memory area.

Example of a table:

| | | | |
|-----|---|-----|---------------------------------------|
| 001 | = | F18 | (factory program) |
| 002 | = | 105 | (user-programm) |
| 003 | = | 030 | (several MIDI program numbers can |
| 004 | = | 030 | be given the same DRP program |
| 005 | = | 030 | numbers) |
| 006 | = | F99 | |
| 007 | = | F01 | (the order and succession of the |
| 008 | = | 005 | programs can be determined at random) |
| 098 | = | -- | (MIDI program numbers are ignored) |
| 128 | = | F88 | |

9.2.3 MIDI DUMP

This function allows the transmission of program data, all user programs or all system data and table setups via MIDI.

To do so you must connect the MIDI OUT socket of the DRP15 with the MIDI IN socket of the receiving device (another DRP15, computer etc.).

The display shows e.g. the following message:

F 01

MIDI DATA DUMP
 Current Program

The following items can be selected with the rotary encoder:

- Current Program** - data of the current program are transmitted.
- All User Programs** - data of all user programs (001 - 128) are transmitted completely.
- System Data +Tab** - Here all system data (e.g. OPTION setups) and all table contents (footswitch table, MIDI table) are transmitted via the MIDI interface.

Pressing the rotary encoder (=ENTER) activates MIDI DUMP and the selected items are transmitted.

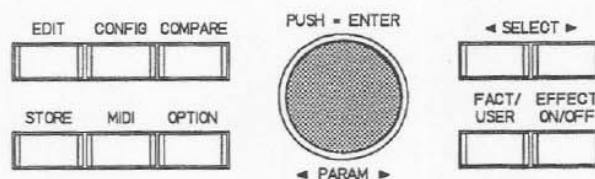

During transmission the display shows:

F 01

Sending MIDI
 Data Dump...

The transmission of all user data lasts approx. 8 sec. Then the previous display appears.

9.2.4 MIDI IN MONITOR

In this function, MIDI data received is indicated on the display in the order in which the data was received, e.g.

Here the user also has the possibility to trace errors by checking the outputs of the various MIDI units in turn to see if they are functioning correctly.

F 01

MIDI IN MONITOR
 C0 01 85 01 80

MIDI

9.3 MIDI PATCH MENU

All the DRP 15 parameters can be altered in realtime by any connected MIDI unit. In EDIT mode the MIDI controllers are assigned to the effect parameters. This assignment is called Controller Patch.

A patch consists of a controller and its control range (range: -100%+100%) and its assigned effect parameter. Up to 4 controller patches can be edited for each program. If a fifth patch is set, the first patch is erased.

The settings are only valid for the appropriate program and are saved in the memory together with the parameters.

In addition to the MIDI controllers and other MIDI messages a foot pedal can be used as a controller (see chapter 10 "REMOTE CONTROL"). "DRP Pedal" must be adjusted as the controller, the control range also being -100%+100%.

The following controllers are available:

| | |
|------------------------------------|------------------------------------|
| 0 = Bank Select | 64 = Damper Pedal |
| 1 = Modulation Wheel | 65 = Portamento |
| 2 = Breath Controller | 66 = Sostenuato |
| 3 = Controller 3 | 67 = Soft Pedal |
| 4 = Foot Controller | 68 = Legato |
| 5 = Portamento Time | 69 = Hold 2 |
| 6 = Data Entry | 70 = Sound Controller 1 |
| 7 = Main Volume | 71 = Sound Controller 2 |
| 8 = Balance | 72 = Sound Controller 3 |
| 9 = Controller 9 | 73 = Sound Controller 4 |
| 10 = Pan | 74 = Sound Controller 5 |
| 11 = Expression Controller | 75 = Sound Controller 6 |
| 12 = Effect Controller 1 | 76 = Sound Controller 7 |
| 13 = Effect Controller 2 | 77 = Sound Controller 8 |
| 14 = Controller 14 | 78 = Sound Controller 9 |
| 15 = Controller 15 | 79 = Sound Controller 10 |
| 16 = General Purpose Controller #1 | 80 = General Purpose Controller #5 |
| 17 = General Purpose Controller #2 | 81 = General Purpose Controller #6 |
| 18 = General Purpose Controller #3 | 82 = General Purpose Controller #7 |
| 19 = General Purpose Controller #4 | 83 = General Purpose Controller #8 |
| 20 = Controller 20 | 84 = Portamento |
| 21 = Controller 21 | 85 = Switch 85 |
| 22 = Controller 22 | 86 = Switch 86 |
| 23 = Controller 23 | 87 = Switch 87 |
| 24 = Controller 24 | 88 = Switch 88 |
| 25 = Controller 25 | 89 = Switch 89 |
| 26 = Controller 26 | 90 = Switch 90 |
| 27 = Controller 27 | 91 = Effect 1 Depth |
| 28 = Controller 28 | 92 = Effect 2 Depth |
| 29 = Controller 29 | 93 = Effect 3 Depth |
| 30 = Controller 30 | 94 = Effect 4 Depth |
| 31 = Controller 31 | 95 = Effect 5 Depth |
| | Note Off |
| | Note On |
| | Poly Pressure |
| | Velocity |
| | Release |
| | Channel Pressure |
| | Pitch Wheel |
| | DRP15 Pedal |

You can only enter the MIDI patch menu from the edit mode. First you must press button EDIT (10) and then button MIDI (7). The LEDs EDIT and MIDI light up.

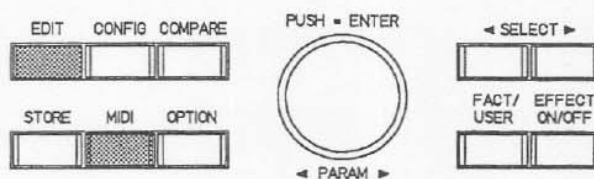

The display will read e.g.:

F 01

EQ LOW
Control is off

This means that no MIDI controller is currently assigned to the parameter EQ LOW.

If you want to assign a MIDI controller to the parameter shown, you select the desired controller with the rotary encoder. You can use the buttons SELECT (16) and (17) in order to select another parameter.

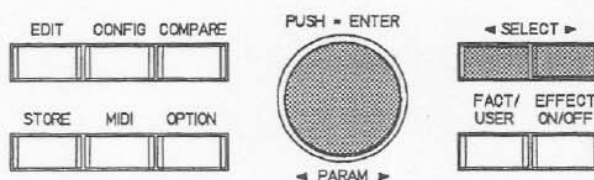

F 01

EQ LOW
C:1 = Modulation

During selection of a MIDI controller with the rotary encoder, the display first shows the name of the controller (see table), and then, after approx. 1 sec., the controller number together with the range, e.g.:

F01

EQ LOW
C: 1 R +100%

First of all set the desired MIDI controller and change to the range value with the button SELECT > (17). You can set the range between -100% and +100% using the rotary encoder.

Range shows the control range in %. Negative values lower the parameters, positive values setting the parameters up respectively. 100% always corresponds with the total range of the parameter in question.

Example:

If the parameter REVERB LEVEL is set to -6 dB and the MIDI controller 1 (Mod. Wheel) is programmed to -50%, the REVERB LEVEL can be changed from -6 dB to -30 dB with the modulation wheel of the keyboard.

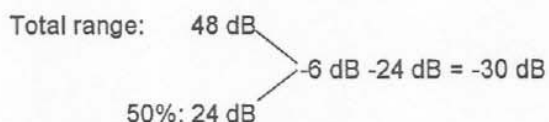

You can change between controller number and range at any time with the SELECT buttons. If the cursor is already on range, you can enter the next parameter with the button SELECT > (17).

Once the desired MIDI patches have been set, you can save the program on a USER memory place as described in chapter 5.4.

IMPORTANT!

Please make sure that the MIDI channel of the transmitting unit always corresponds with the receive channel of the DRP 15. MIDI control is not possible otherwise.

MIDI

9.4 MIDI DATA FORMAT

This chapter contains information to enable programmers, to write software for the DRP 15. Here all commands are defined which are necessary for transmitting and sending data via the MIDI interface.

MIDI data communication is possible only if a MIDI receive channel is set (OMNI, 1 - 16). If MIDI RECEIVE CHANNEL is set to OFF, no communication is possible via the MIDI interface (see chapter 9.2.1).

General MIDI commands:

| Program Change | MIDI-Byte | description |
|----------------|-----------------------------|--|
| | Cn (hex) 0xxx xxxx (bin) | n = MIDI Channel 0-15 Bank 0: 0..127 = User 1..128 Bank 1: 0..99 = Factory 0..99 100..127 = Factory 0 |

In the MIDI program table any assignment of MIDI program numbers to the DRP 15 programs is possible (see chapter 9.2.2).

| Bank Select (Controller 0) | MIDI-Byte | description |
|-------------------------------|-----------------------------------|--|
| | Bn (hex) 20 0000 000n (bin) | n = MIDI Channel 0-15 Controller 0 (LSB) n = 0: User Bank, n = 1: Factory Bank |

The USER or FACTORY bank is selected with controller 0. The alteration takes effect with the next program change.

MIDI System Exclusive Implementation:

| Identity Request (recognized) | MIDI-Byte | description |
|----------------------------------|--|---|
| | F0 (hex) 7E 0n 06 01 F7 | System Exclusive Universal System Exclusive Non-real time header n = MIDI Channel 0-15 (7F = All Channels) General Information Identity Request End of SysEx Message |

This command requests the DRP 15 to transmit the ID number.

| Identity Reply (transmitted when Identity Request is received) | MIDI-Byte | description |
|---|--|--|
| | F0 (hex) 7E 0n 06 02 30 0F DEV_CODE REVISION F7 | System exclusive Universal System Exclusive Non-real time header n = MIDI Channel 0-15 (7F = All Channels) General Information Identity Reply DYNACORD ID: No 48 DRP 15 ID: No 15 Reserved 3 Byte Device code Revision: 4 Digit ASCII Code End of SysEx Message |

The DRP 15 transmits this ID as answer to an Identity Request. The DYNACORD ID No. 48, the DRP device ID No. 15, an 3-byte device code, and the Revision No. are transmitted.

Dumps:

| Current Program Dump Request | MIDI-Byte | description |
|------------------------------|-----------|---|
| (recognized) | F0 (hex) | System exclusive |
| | 30 | DYNACORD ID: No 48 |
| | 0n | n = MIDI Channel 0-15 (7F = All Channels) |
| | 0F | DRP 15 ID: No 15 |
| | 11 | Function ID: Current Program Dump Request |
| | F7 | End of SysEx Message |

This command requests the DRP 15 to transmit the program currently in the buffer.

| Current Program Dump | MIDI-Byte | description |
|------------------------------|-----------|--|
| (recognized +transmitted) | F0 (hex) | System exclusive |
| | 30 | DYNACORD ID: No 48 |
| | 0n | n = MIDI Channel 0-15 (7F = All Channels) |
| | 0F | DRP 15 ID: No 15 |
| | 31 | Function ID: Current Program Dump |
| | DATA | 8/7 Code (72 Data Byte) |
| | CHECKS | Checksum of Received DATA (7 bit, 2's Compl) |
| | F7 | End of SysEx Message |

The program currently in the buffer is transmitted or received.
USER programs are not altered!

| Single Program Dump Request | MIDI-Byte | description |
|-----------------------------|----------------------|---|
| (recognized) | F0 (hex) | System exclusive |
| | 30 | DYNACORD ID: No 48 |
| | 0n | n = MIDI Channel 0-15 (7F = All Channels) |
| | 0F | DRP 15 ID: No 15 |
| | 14 | Function ID: Single Program Dump Request |
| | 0000 000x (bin) | x = 0: User Bank, x = 1: Factory Bank |
| | 0xxx xxxx | Source: No. 0..127 = User 1..128 (Bank 0) No. 0..99 = Factory 0..99 (Bank 1) |
| | 0xxx xxxx | Destination: Nr 0..127 = User 1..128 |
| F7 | End of SysEx Message | |

This command requests the DRP 15 to transmit a program specified by bank and program number.

| Single Program Dump | MIDI-Byte | description |
|------------------------------|----------------------|--|
| (recognized +transmitted) | F0 (hex) | System exclusive |
| | 30 | DYNACORD ID: No 48 |
| | 0n | n = MIDI Channel 0-15 (7F = All Channels) |
| | 0F | DRP 15 ID: No 15 |
| | 34 | Function ID: Single Program Dump |
| | 0xxx xxxx (bin) | Destination: No 0..127 = User 1..128 |
| | DATA | 8/7 Code (72 Data Byte) |
| | CHECKS | Checksum of Received DATA (7 bit, 2's Compl) |
| F7 | End of SysEx Message | |

The program defined by program numbers is transmitted or received.
The appropriate USER program is be overwritten.

MIDI

| | MIDI-Byte | description |
|---|-----------|---|
| All User Programs Dump Request (recognized) | F0 (hex) | System exclusive |
| | 30 | DYNACORD ID: No 48 |
| | 0n | n = MIDI Channel 0-15 (7F = All Channels) |
| | 0F | DRP 15 ID: No 15 |
| | 12 | Function ID: All Programs Dump Request |
| | F7 | End of SysEx Message |

This command requests the DRP 15 to transmit all 128 USER programs.

| | MIDI-Byte | description |
|--|-----------|--|
| All User Programs Dump (recognized + transmitted) | F0 (hex) | System exclusive |
| | 30 | DYNACORD ID: No 48 |
| | 0n | n = MIDI Channel 0-15 (7F = All Channels) |
| | 0F | DRP 15 ID: No 15 |
| | 32 | Function ID: All Programs Dump |
| | DATA | 8/7 Code (9216 Data Byte) |
| | CHECKS | Checksum of Received DATA (7 bit, 2's Compl) |
| | F7 | End of SysEx Message |

The DRP 15 transmits or receives all 128 USER programs.

This procedure lasts approx. 8 sec.

All USER programs are overwritten. The program currently in the buffer is not altered!

| | MIDI-Byte | description |
|--|-----------|---|
| System Data + Tables Dump Request (recognized) | F0 (hex) | System exclusive |
| | 30 | DYNACORD ID: No 48 |
| | 0n | n = MIDI Channel 0-15 (7F = All Channels) |
| | 0F | DRP 15 ID: No 15 |
| | 13 | Function ID: System Data Dump Request |
| | F7 | End of SysEx Message |

This command requests the DRP 15 to transmit all system data and contents of tables.

| | MIDI-Byte | description |
|--|-----------|--|
| System Data + Tables Dump (recognized +transmitted) | F0 (hex) | System exclusive |
| | 30 | DYNACORD ID: No 48 |
| | 0n | n = MIDI Channel 0-15 (7F = All Channels) |
| | 0F | DRP 15 ID: No 15 |
| | 33 | Function ID: System Data Dump |
| | DATA | 8/7 Code (256 Data Byte) |
| | CHECKS | Checksum of Received DATA (7 bit, 2's Compl) |
| | F7 | End of SysEx Message |

Here no program data are transmitted, but only system data as in OPTION mode or in the MIDI program table.

| Dump Processed | MIDI-Byte | description |
|-------------------------------|--|--|
| (recognized + transmitted) | F0 (hex) 30 0n 0F 20 F7 | System exclusive DYNACORD ID: No 48 n = MIDI Channel 0-15 (7F = All Channels) DRP 15 ID: No 15 Function ID: Dump Processed End of SysEx Message |

This information is transmitted if a dump has been received and processed.

Others:

| Store Request | MIDI-Byte | description |
|---------------|---|---|
| (recognized) | F0 (hex) 30 0n 0F 15 0xxx xxxx (bin) F7 | System exclusive DYNACORD ID: No 48 n = MIDI Channel 0-15 (7F = All Channels) DRP 15 ID: No 15 Function ID: Store Request Destination No. 0 - 127 = User 1 - 128 End of SysEx Message |

Here the current buffer contents are stored under the specified USER program number.

| Store Processed | MIDI-Byte | description |
|-------------------------------|--|---|
| (recognized + transmitted) | F0 (hex) 30 0n 0F 25 F7 | System exclusive DYNACORD ID: No 48 n = MIDI Channel 0-15 (7F = All Channels) DRP 15 ID: No 15 Function ID: Store Processed End of SysEx Message |

Is transmitted once the store process has been concluded.

| Single Parameter adjust | MIDI-Byte | description |
|-------------------------------|---|--|
| (recognized + transmitted) | F0 (hex) 30 0n 0F 30 0nnn nnnn (bin) 0xxx xxxx 0xxx xxxx F7 | System exclusive DYNACORD ID: No 48 n = MIDI Channel 0-15 (7F = All Channels) DRP 15 ID: No 15 Function ID: Parameter adjust Parameter Number (s. Table) 7 bit Data LSB (0-127) 7 bit Data MSB (not necessary) End of SysEx Message |

Here a certain parameter of the current buffer program is altered.

MIDI

Parameter Numbers (decimal):

| | | | | |
|----|------------------|------------------|---------------|---------------|
| 0 | ORIGINAL LEVEL | | | |
| 1 | EQ LOW | | | |
| 2 | EQ HIGH | | | |
| 3 | REVERB LEVEL | | PITCH1 LEVEL | |
| 4 | REVERB TYPE | | PITCH1 PAN | |
| 5 | REVERB ROOM SIZE | | PITCH1 DETUNE | |
| 6 | REVERB TIME | | PITCH1 FINE | |
| 7 | REVERB LF DAMP | | | |
| 8 | REVERB HF DAMP | | | |
| 9 | REFL-REV RATIO | DELAY LEVEL | | |
| 10 | REFLECTION TYPE | DELAY TYPE | | |
| 11 | REV-CLUSTER PROP | DELAY TIME | | |
| 12 | REVERB PREDELAY | DELAY FEEDBACK | | |
| 13 | REFL-REV DELAY | MODULATION LEVEL | PITCH2 LEVEL | PITCH BALANCE |
| 14 | REVB GATE TIME | MODULATION TYPE | PITCH2 PAN | |
| 15 | REVB GATE COLOR | MODULATION DEPTH | PITCH2 DETUNE | PITCH DETUNE |
| 16 | REVB GATE SLOPE | MODULATION SPEED | PITCH2 FINE | PITCH FINE |
| 17 | REVB GATE PREDLY | MODULATION FEEDB | PITCH TYPE | |
| 18 | DISTORTION | | | |
| 19 | VOICE FILTER | | | |
| 20 | EFFECT LEVEL | | | |

| MIDI Remote Control | MIDI-Byte | description |
|---------------------|-----------|---|
| (recognized) | F0 (hex) | System exclusive |
| | 30 | DYNACORD ID: No 48 |
| | 0n | n = MIDI Channel 0-15 (7F = All Channels) |
| | 0F | DRP 15 ID: No 15 |
| | 77 | Function ID: Remote (119) |
| | 0n | Remote Code (s. Table) |
| | F7 | End of SysEx Message |

This command allows remote control of the control elements (buttons, rotary encoder). The DRP 15 reacts just as if the operation had been performed via the front panel.

Remote Codes (decimal):

| | |
|----|--------------|
| 1 | EDIT |
| 2 | CONFIG |
| 3 | COMPARE |
| 4 | STORE |
| 5 | DOWN |
| 6 | FACTORY |
| 7 | MIDI |
| 8 | OPTION |
| 9 | UP |
| 10 | EFF-OFF |
| 11 | SERVICE |
| 15 | ENTER |
| 16 | ENCODER-DOWN |
| 17 | ENCODER-UP |

MIDI Implementation Chart

| Function.. | Transmitted | Recognized | Remark |
|---|---|---------------------------------|--------------------------------------|
| Basic Default Channel Changed | X X | 1-16, -OFF- 1-16, -OFF- | Memorized |
| Mode Default Messages Altered | X X | Mode 1,3 X | Memorized |
| Note Number True voice | X | 0-127 | Used as Controller |
| Velocity Note ON Note OFF | X X | O O | Used as Controller |
| After Key's Touch Ch's | X X | O O | Used as Controller |
| Pitch Bend | X | O | Used as Controller |
| Control Change | X | 0-31 64-95 32 | Used as Controller Bank Select |
| Prog Change True# | X | 0 - 127 001- 128 F00- F99 | User Bank Factory Bank |
| System Exclusive | O | O | |
| System Song Pos Common Song Sel Tune | X X X | X X X | |
| System Clock Real Time Commands | X X | X X | |
| Aux Local ON/OFF Messages All Notes OFF Active Sense Reset | X X X X | X X X O | |
| Notes | | | |
| Mode 1 : OMNI ON, POLY Mode 3 : OMNI OFF, POLY | Mode 2 : OMNI ON, MONO Mode 4 : OMNI OFF, MONO | O : Yes X : No | |

REMOTE CONTROL

10 REMOTE CONTROL

10.1 REMOTE CONNECTIONS

With the DRP 15, the user has the possibility to use remote control of various functions via foot switch or pedal. The remote sockets are located at the rear of the housing.

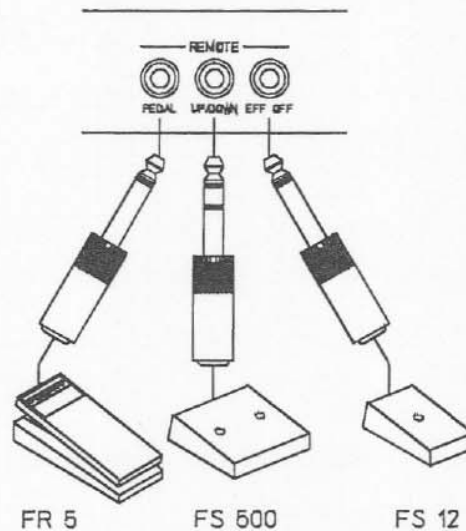

- UP/DOWN** - When connecting a double foot switch FS500 to this socket, the DRP 15's programs can be switched over. The order is fixed in the OPTION Menu. The program selected is loaded immediately.
- EFF OFF** - If a foot switch FS 12 is connected to this socket the Effect Off function can be activated. This is indicated by the Effect Off LED (also see chapter 5.5, EFFECT-ON/OFF- FUNCTION).
- PEDAL** - If a foot pedal FR 5 is connected to this socket, this serves to control parameters such as volume in real time. The parameter can be programmed separately for every program. Turn to chapter 7 for a more detailed explanation 9.3.

NOTE:

Models other than the specified FS 500 and FS 12 can also be used as foot switches. Prerequisite is that the other foot switches have momentary contacts and not switches, and that the contact closes when the foot switch is pushed (ON).

The foot pedals used should have a rated resistance between 75 kohms and 150 kohms. The control range should be between 0 ohms and the rated resistance.

11 APPENDIX

11.1 HOW IS REVERBERATION PRODUCED?

A sound signal is produced off by the sound source A. First the direct signal (double arrow) reaches the ear of listener B. With varying delay times the first reflections (single arrows) are then perceived (as echoes in larger rooms). The actual reverberation (open arrows) is then created by a very high density of many different time-delayed reflections. Within the reverberation the ear does not perceive the individual reflections as such. Depending on the wall structure, (or the reflecting object), a completely irregular diffusion can occur as shown at reflection point C.

The **duration** of the reverb mainly depends on the size of the room and the absorption qualities of its walls. In a large room the reflections travel further which of course takes longer.

The **reverb density** mainly depends on the properties of the room. An uneven or angular room gives off more varying reflections than a cube-shaped room for example.

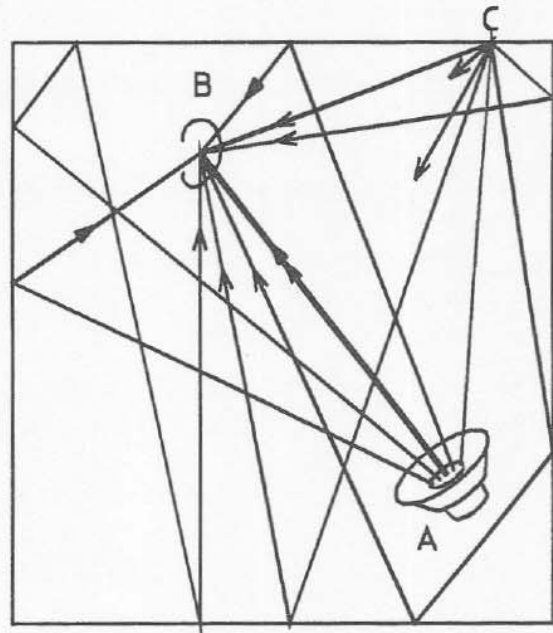

The timing of a reverb signal.

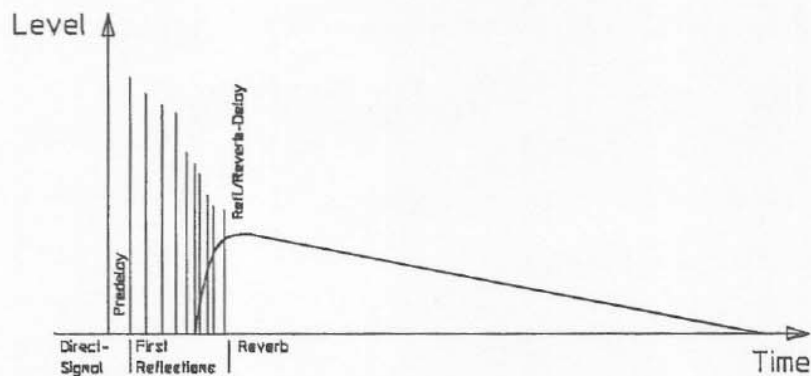

(Turn to chapter 7 to see the tasks of the individual parameters with the DRP 15)

APPENDIX

11.2 WHAT IS MIDI?

As the name suggests, MIDI (Musical Instrument Digital Interface) is a standard data interface for musical instruments and devices.

In the general MIDI standard, MIDI Controllers, MIDI switches, MIDI Note numbers etc. are determined. As in computer technology, every MIDI event is given a certain address (bit order) which is recognized by all MIDI interfaces alike. Thus MIDI means a language which is also understood by units made by different manufacturers.

In most cases a MIDI is used to play devices which produce sound (such as Expanders, Samplers, Synthesizers etc) from a keyboard. MIDI is used to transmit information to the units connected. Such information may include the note played, the position of the modulation wheel, the position of a foot pedal, the velocity with which the keys are played etc.

Effect units such as the DRP 15 can also be controlled via MIDI. They can be programmed in such a way that when a synthesizer sound is called up, the matching effect is also always selected. This is possible because when choosing a sound, the synthesizer transmits a program change command which is received by the DRP 15, which then calls up the program allocated to that particular command.

16 different channels are defined in the MIDI standard. Thus a MIDI transmitter can control up to 16 different MIDI reception devices at the same time, completely independently. You can set the MIDI reception channel on the DRP 15 (see chapter 9.2.19).

For a correct MIDI operation the user must make sure that the appropriate MIDI channel is also set on the transmitting unit (Keyboard, Sequencer, Computer). Please read the operating instructions of the units in question.

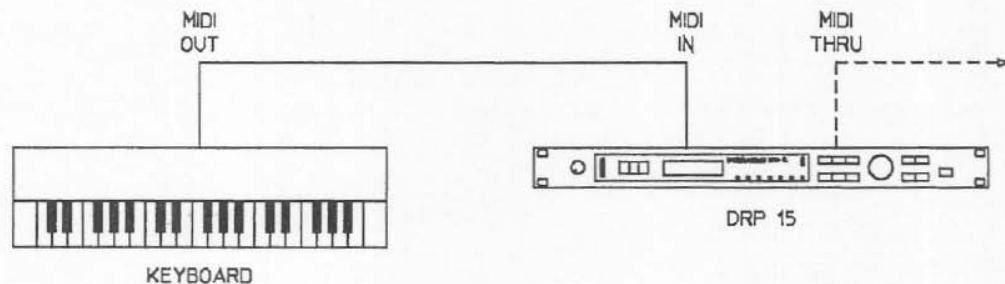

12.1 SPECIFICATIONS

| | | |
|---------------------------|---|-------------------|
| Mains voltage | 90 - 250 VAC / 50 - 60 Hz (without switching) | |
| Power consumption | max. 15 W | |
| Safety class | I | |
| Rated input voltage | LINE | 1.23 V / +4 dBu |
| | INSTR | 390.mV / -6 dBu |
| Max. input voltage | 9 V / +21 dBu | |
| Input impedance | LINE | 10 kohms |
| | INSTR | 500 kohms |
| Rated output voltage | HI | 2.45 V / +10 dBu |
| | LO | 730 mV / -0.5 dBu |
| Max. output voltage | 9 V / +21 dBu | |
| Output impedance | 120 ohms | |
| Frequency response direct | 20 Hz - 20 kHz | +0 /-1 dB |
| Frequency response effect | 20 Hz - 20 kHz | +0 /-2 dB |
| S/N ratio direct | > 104 dB | |
| S/N ratio effect | > 90 dB | |
| Distortion (THD) direct | < 0.003% | |
| Distortion (THD) effect | < 0.03% | |
| Data format | 16 bit linear, internal 24 bit | |
| MIDI connectors | IN/OUT/THRU | |
| Display | 2 x 16 digit alpha-numerical LCD with LED back lit | |
| Ground Lift | Disconnects ground from housing | |
| Dimensions (W X H X D) | 483 x 43.6 x 225 mm; 19" with 1 HU | |
| Weight | 3.5 kg / 7.7 lbs | |
| Options | FS 500 (Up/Down) | |
| | FS 12 (Effect off) | |
| | FR 5 (Pedal) | |

The specifications for this product are subject to change without prior notice.